



Harvest Radiant Installation Manual

2026-06-16

Installation Manual

Before You Begin

1. System Overview
2. Compatibility
3. Safety

Components

1. Heat Pump Water Heater - SANCO2
2. Tank
3. Harvest Pod
4. Radiant Heat Exchanger
5. Integrating DHW Recirculation

Plumbing

1. Single SANCO2 Plumbing Diagram
2. Twin SANCO2 Plumbing Diagram
3. Double-Tank Plumbing Diagram

Insulation

Cold Climate Installations

Low Voltage Wiring

1. SANCO2 Low Voltage Wiring
2. Low Voltage Wiring Diagram
3. Twin-SANCO2 Heat Output Sensor Wiring

Start Up

1. Hydronic System Start Up
2. Thermal Battery System Start Up

Troubleshooting

Before You Begin

Note

Always check for the most up-to-date installation information, which can be found at <http://docs.harvest-thermal.com/>. Similarly, all SANCO2 installation material provided in this manual is for convenience only. Refer to SANCO2 for the most up-to-date and complete installation information on the SANCO2 heat pump water heater and tank.

- **System Overview**
- **Compatibility**
- **Safety**

System Overview

Floor Design and Sizing

The Harvest Radiant system is considered a low-temperature radiant system. As such, there are a few practices that can help get the best performance out of a lower temperature radiant floor:

- Use longer loop length than typical to help achieve a low return temperature, e.g., 250-500 ft length.
- Use a “double back” layout, i.e. the warm supply pipe is always next to the cooler return pipe to achieve a uniform temperature across the floor

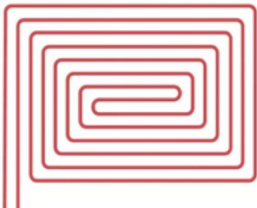

Optimal piping layout

The higher the radiative transfer capacity of the floor, the better system performance and efficiency will be. In addition, the calculated heating capacity of the floor should always exceed the design load of the building.

Calculate the heating capacity of the floor: $\text{Floor capacity} = \text{heat flux (BTU/sqft/hr)} * \text{heated floor area (sqft)}$

Heat Flux (BTU/sqft/hr)		Flooring		
		Polished concrete or tile	Wood	Carpet or area rug
Radiant transfer material	Concrete	30	15	5
	Engineered radiant	20-30	10-15	3-5
	Staple-up	10	5	2

⋮

Plumbing Overview

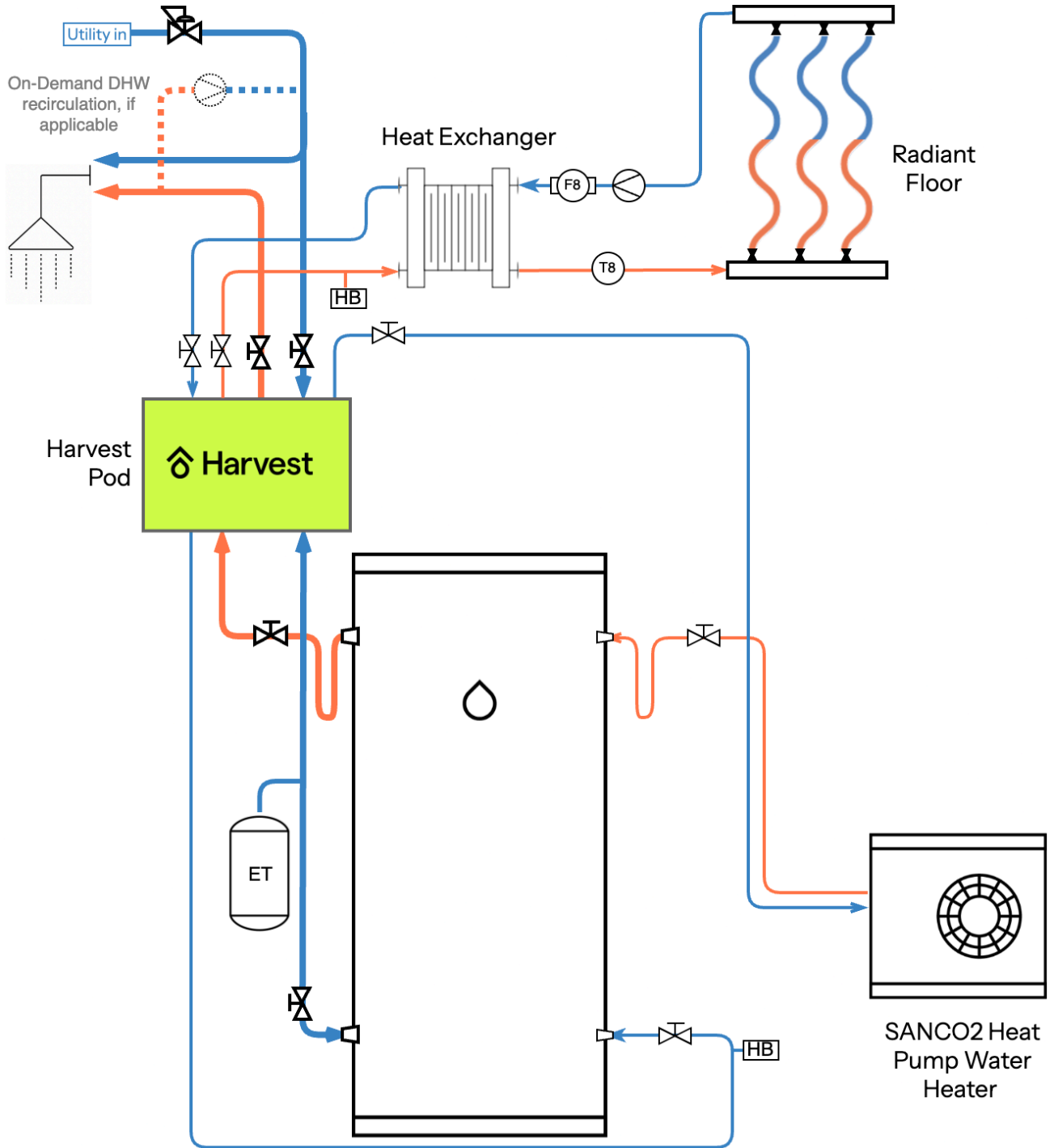

⋮

Wiring Overview

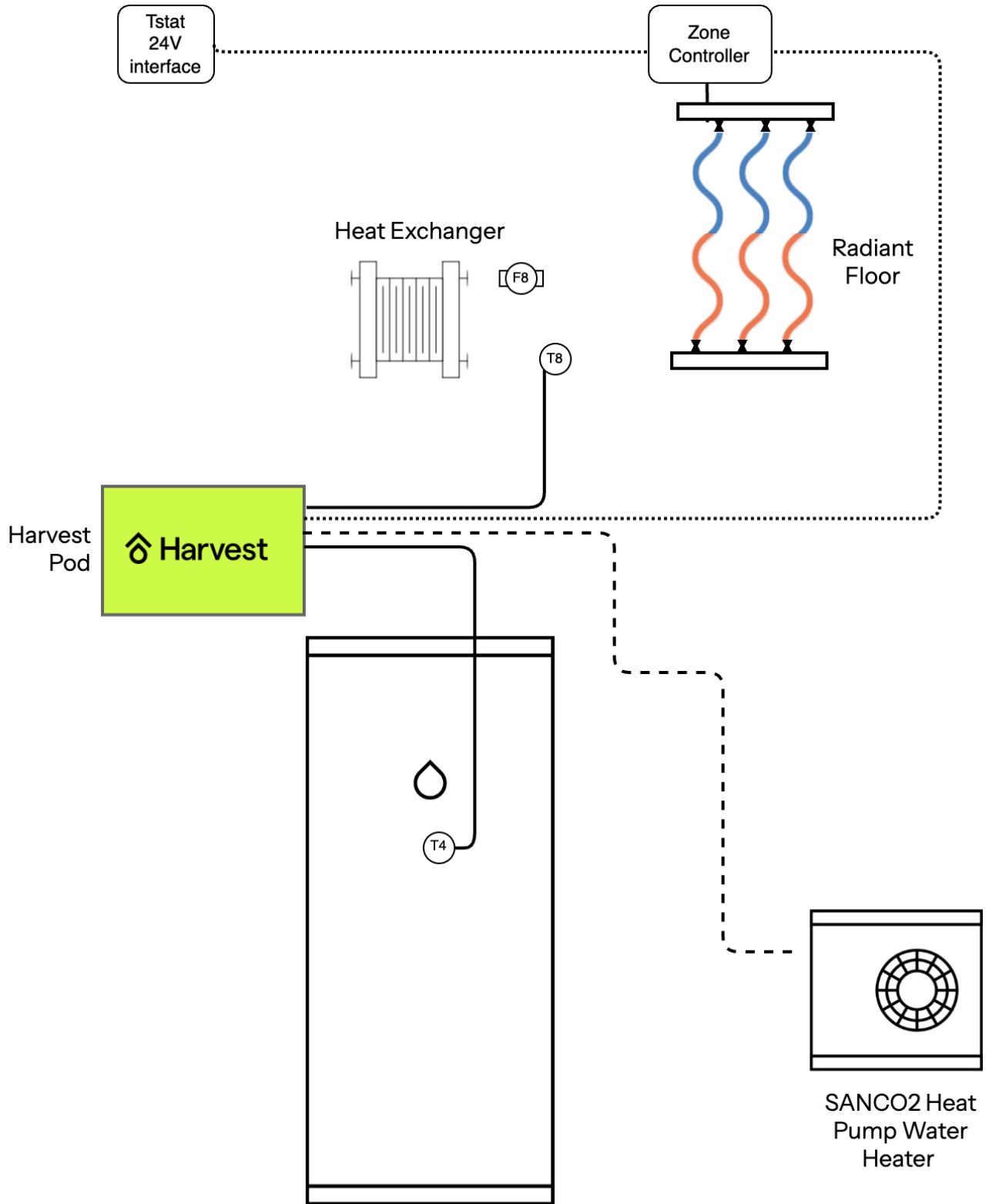

Compatibility

Harvest Radiant is compatible with:

SanCO2 heat pumps and tanks for hydronic heating and hot water

Concrete/gypcrete and engineered radiant floor systems

Up to two SanCO2 heat pumps

Up to two thermal storage tanks

On-demand hot water recirculation pumps

Solar PV, batteries, smart electric panels (not required)

Harvest Radiant is NOT compatible with:

Non-SANCO2 heat pumps and tanks for hydronic heat and hot water

Staple-up radiant systems

Continuous or timer-controlled hot water recirculation pumps

Solar thermal integrated with the Harvest system

Refer to [Harvest Radiant Technical Specifications](#) for equipment specifications and to aid in full system design.

Safety

Danger

HAZARD WARNINGS: These symbols call attention to warnings, electric shock hazards, and gas hazards respectively, and directions that must be followed for safety reasons.

Danger

WARNING: The installation manual instructions are intended as an aid to qualified service personnel for proper installation, adjustment and operation. Read these safety requirements thoroughly before attempting installation or operation. It is the responsibility of the installer to follow all national codes, standards and local ordinances. The installation must comply with regulations of the local building, heating, plumbing, and other codes. where local codes are not applicable, the installation must comply with the national codes and any and all authorities having jurisdiction. Failure to follow these requirements may result in improper installation, adjustment, service or maintenance, possibly resulting in fire, electrical shock, carbon monoxide poisoning, explosion, property damage, personal injury or death.

Danger

California Proposition 65 WARNING: This product contains chemicals known to the State of California to cause cancer, birth defects or other reproductive harm

Safety Requirements

General

Danger

ELECTRICAL SHOCK HAZARD: Confirm all circuits are de-energized before performing any wiring activity

Heat Pump/Tank

Caution

WARNING: Use caution when installing heavy equipment. To avoid injury, follow the manufacturer's installation instructions regarding all safety protocols.

Radio Interference

Caution

WARNING: This equipment has been tested and found to comply with the limits for a Class B digital device pursuant to Part 15 of the FCC Rules. These limits are designed to provide reasonable protection against harmful interference in a residential installation. This equipment generates, uses, and can radiate radio frequency and, if not installed and used in accordance with the instructions, may cause harmful interference to radio communications. However, there is no guarantee that interference will not occur in a particular installation. If this equipment does cause harmful interference to radio or television reception, which can be determined by turning the equipment on and off, the user is encouraged to try and correct the interference by one or more of the following measures:

- Reorient or relocate the receiving antenna.
- Increase the separation between the equipment and the receiver.
- Connect the equipment into an outlet of on a circuit different from that to which the receiver is connected.
- Consult the dealer or an experienced radio/TV technician for help.

Harvest Thermal
1831 Solano Avenue
#8611
Berkeley, CA 94707
<https://www.harvest-thermal.com/>

declare under our sole responsibility that the product

Harvest Pod

complies with Part 15 of FCC Rules. Operation is subject to the following two conditions:

1. this device may not cause harmful interference, and
2. this device must accept any interference received, including interference that may cause undesired operation

Components

- **Heat Pump Water Heater - SANCO2**
 - Single SANCO2 Heat Pump Setup
 - Twin-SANCO2 Additional Setup Information
- **Tank**
- **Harvest Pod**
- **Radiant Heat Exchanger**
- **Integrating DHW Recirculation**

Heat Pump Water Heater - SANCO2

Caution

WARNING: Installation instructions in this manual are not meant to encompass 100% of SANCO2 installation guidelines and requirements. Refer to the manufacturer for complete instructions.

Single SANCO2 Heat Pump Setup

Twin-SANCO2 Additional Setup Information

Single SANCO2 Heat Pump Setup

Location

The SANCO2 heat pump should:

- Be located **no further than 66ft (20m) from the tank**, and **no more than 23ft (7m) above it**. Additionally, minimizing pipe length to the tank/pod maximizes efficiency
- Maximum **6 bends**, use **long-radius elbows**, not “street Ls”
- Be installed outside, with adequate ventilation (see [Required Unit Clearances](#))
- Be installed in such a way where water can drain without damaging the heat pump

Note

The SANCO2 heat pump operates most efficiently when located on the East or South side of the property.

The heat pump can be installed either on a:

- Preferably a pad or other firm base, or
- On wall-mounted brackets.

Caution

WARNING: While the SANCO2 is rated max 37dB, noise due to unit vibration may be a nuisance when wall-mounted.

WARNING: If ground-mounted, mount it on risers or pump-ups, to enable access to the drain valve under the unit.

Dimensions

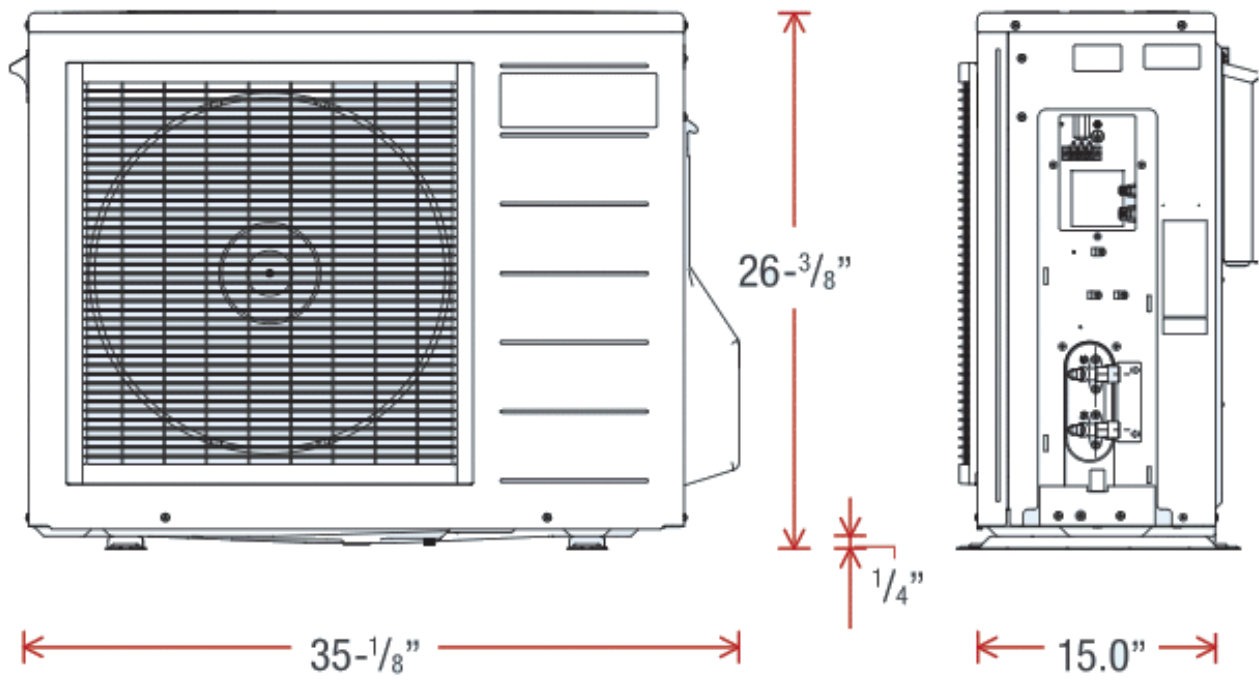

Source: SANCO2 GS4 Installation Manual

Required Unit Clearances

Flat wall installation

Caution: Water fitting side must have 12" clearance.
24" is desirable

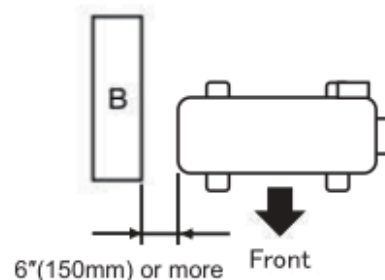
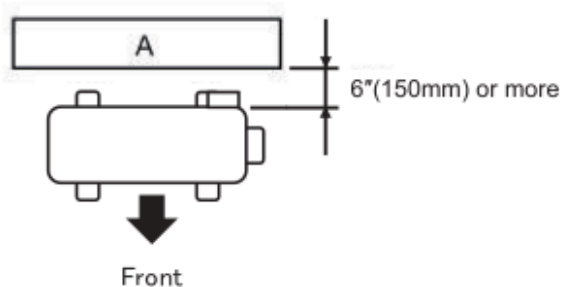

Corner installation

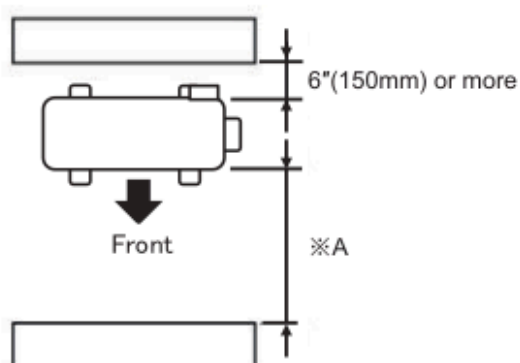
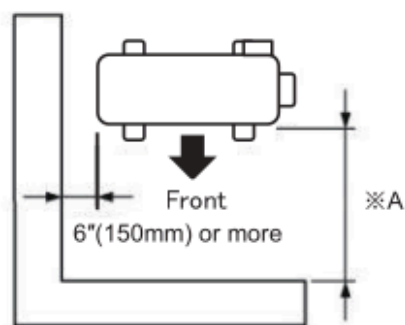

※A 14" (350mm) or more in case of the height of wall is less than 47" (1200mm)
24" (600mm) or more in case of the height of wall is more than 47" (1200mm)

Source: Source: SANCO2 GS4 Installation Manual

Allow 4" of clearance below the heat pump for the drain plug.

Caution

WARNING: Failure to allow proper clearances and ventilation can negatively impact system performance. Additionally, be cognizant of environmental conditions such as vents or other mechanical equipment when selecting the location.

Installation Example and Additional Dimensions

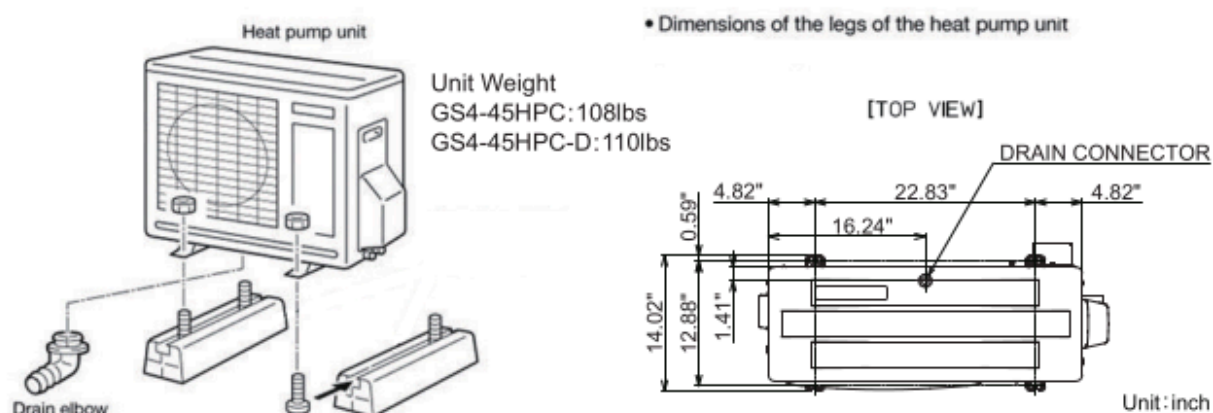

Front Foot

Use 3/8" Diameter Screws

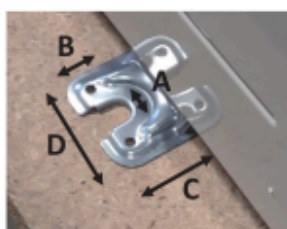

Rear Foot

Use 3/8" Diameter Screws

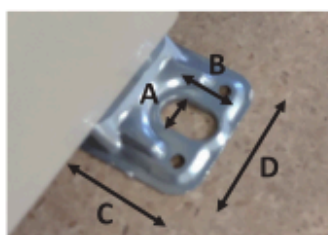

"A" 7/16"
"B" 3/4"
"C" 1"
"D" 2"

Note

Mounting solutions are available directly from ECO2.

Caution

Spring isolators ([example](#)) and vibration isolator pads ([example](#)) should be used if the SANCO2 heat pump is being mounted on a wall connected to the home.

Powering the SANCO2

Caution

WARNING: Installation instructions in this manual are not meant to encompass 100% of SANCO2 installation guidelines and requirements. Refer to the manufacturer for complete instructions.

⚠ Danger

HAZARD: Installation must be carried out by a qualified technician. All Electrical Wiring should be done in accordance with the latest edition of the National Electrical Code (NEC) and all local State/Province and Municipality codes.

Electrical Requirements:

Power Supply: 240V-1Ph-60Hz

Breaker Size: 15A

MCA: 7.2A

A quick disconnect must be installed adjacent to heat pump in accordance to NEC and local codes

Main Power Connection

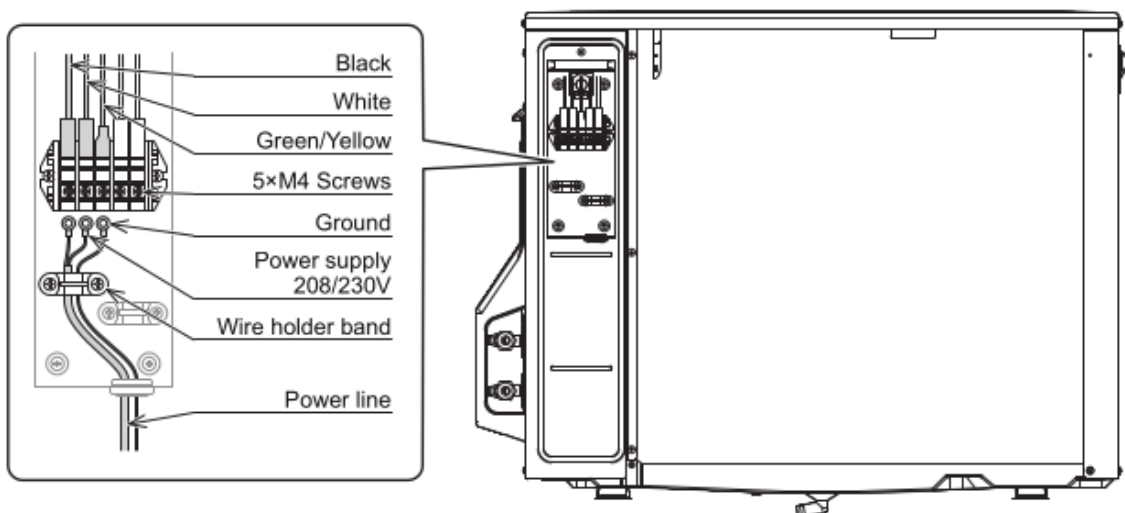

Source: SANCO2 GS4 Installation Manual

💡 Tip

Ensure all power wires (including ground) are securely connected

⚠ Caution

WARNING: DO NOT power heat pump until wiring and plumbing are complete and system has been completely filled and primed. Refer to [Start Up](#).

Refer to [Low Voltage Wiring Diagram](#) for low voltage wiring.

Plumbing Connections

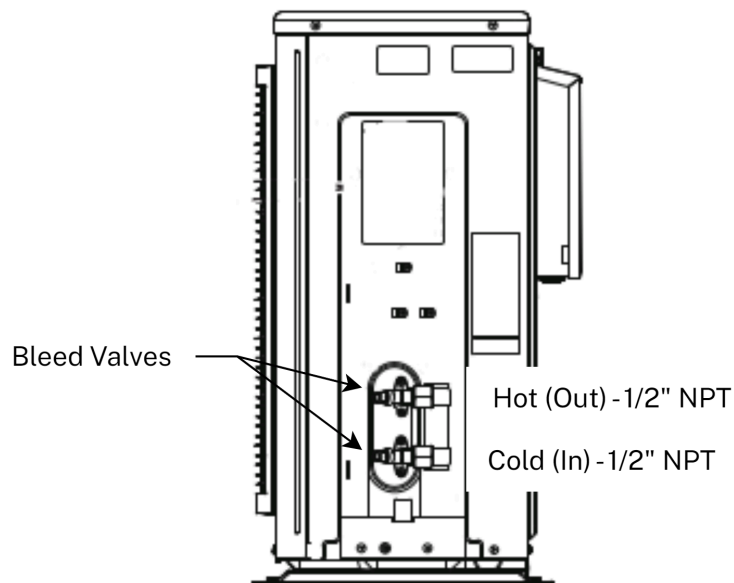

Twin-SANCO2 Additional Setup Information

Note

A Twin-HPWH install kit is required for installation

Required Unit Spacing and Orientation

Heat Pumps should be located such that the air exhausted from one heat pump is not pulled in by the other (see below).

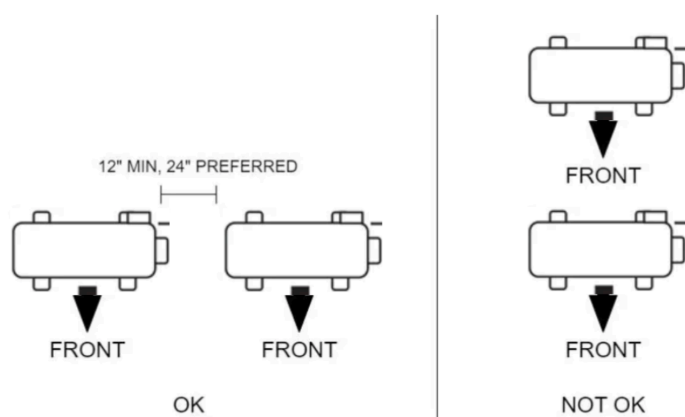

Electrical Requirements:

Provide a subpanel within reach of the twin-HPWH units in accordance to NEC and local codes

Power Supply:	240V-1Ph-60Hz
Main Breaker Size:	30 A
Breaker Size for each SANCO2 unit	15 A

Functional Description

This setup enables the twin heat pumps to function as if there was only one heat pump, but with twice the capacity of a normal HPWH unit.

- The two heat pumps are **plumbed in parallel**.
- A common 3/4" cold supply pipe will run from the pod to a tee with 1/2" connections to each heat pump.
- On the hot return, each heat pump plumbs 1/2" lines to a combining tee with a 3/4" outlet routed to the hot port of the tank.
- Additionally, the heat pumps are **wired to always run at the same time**.

The Harvest Thermal Pod directly controls one heat pump — the primary heat pump — while the second heat pump is controlled by a current sensing switch. This current sensing switch is located only on the power line of primary heat pump, and switches on (turning on SANCO2 - 2) after a minimum amount of current flows to primary heat pump

The thermistor connection to primary heat pump will be typical of a Harvest Thermal single heat pump system, and the secondary heat pump will have a simple resistor installed on its thermistor connection that matches the resistance of the thermistor measuring a “cold” tank temperature.

Caution

Swing check valves must be installed on the return (cold) side of both heat pumps.

Note

It is best practice to make the pipe lengths between the tee's and the heat pumps be as even as possible.

Tank

Caution

WARNING: Installation instructions in this manual are not meant to encompass 100% of SANCO2 installation guidelines and requirements. Refer to the manufacturer for complete instructions.

Location

The tank can be located **no further than 66ft (20m) from the SANCO2 heat pump**, and **no more than 23ft (7m) below it**.

Tank must be installed in an area not subjected directly to outside weather.

Dimensions

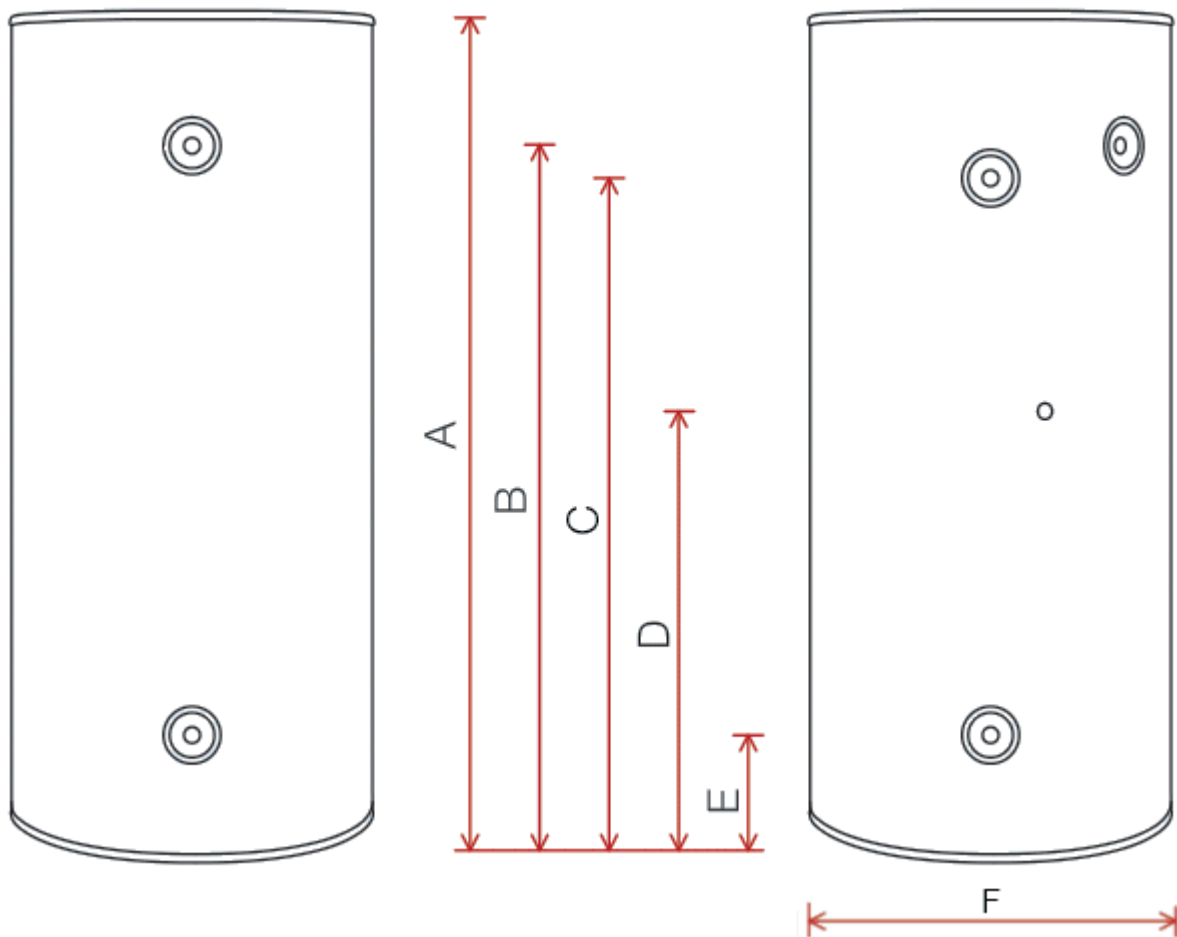

Source: SANCO2 GS4 Installation Manual

Dimension	83 Gal	119 Gal
A: Height	68-7/8"	63-3/8"
B: Hot Water Outlet and PRV	60-1/4"	56"
C: Heat Pump Return	60-1/4"	60-1/4"
D: Sensor Port	40-5/8"	56"
E: Hydronic Return & Cold Water to HP	8-3/4"	4"
F: Diameter	24-1/2"	28"
Dry Weight	115 lbs	345 lbs

Note

NOTE: Allow space between the tank and the wall for tank insulation to be added later.

Mounting

The tank is a passive storage vessel (no internal heating element). Therefore, there is no required:

- Pedestal
- Flue, or
- Condensing section

Note

NOTE: Min. 1" high-density insulation below the tank is *required* (see [Insulation](#) section) for good system performance

Note

NOTE: It is required to wrap R6, or greater, insulation (see [Insulation](#) section) around the tank. It is easiest to do this prior to plumbing it.

Caution

WARNING: Follow all local jurisdiction codes for bracing of tank

Plumbing Connections

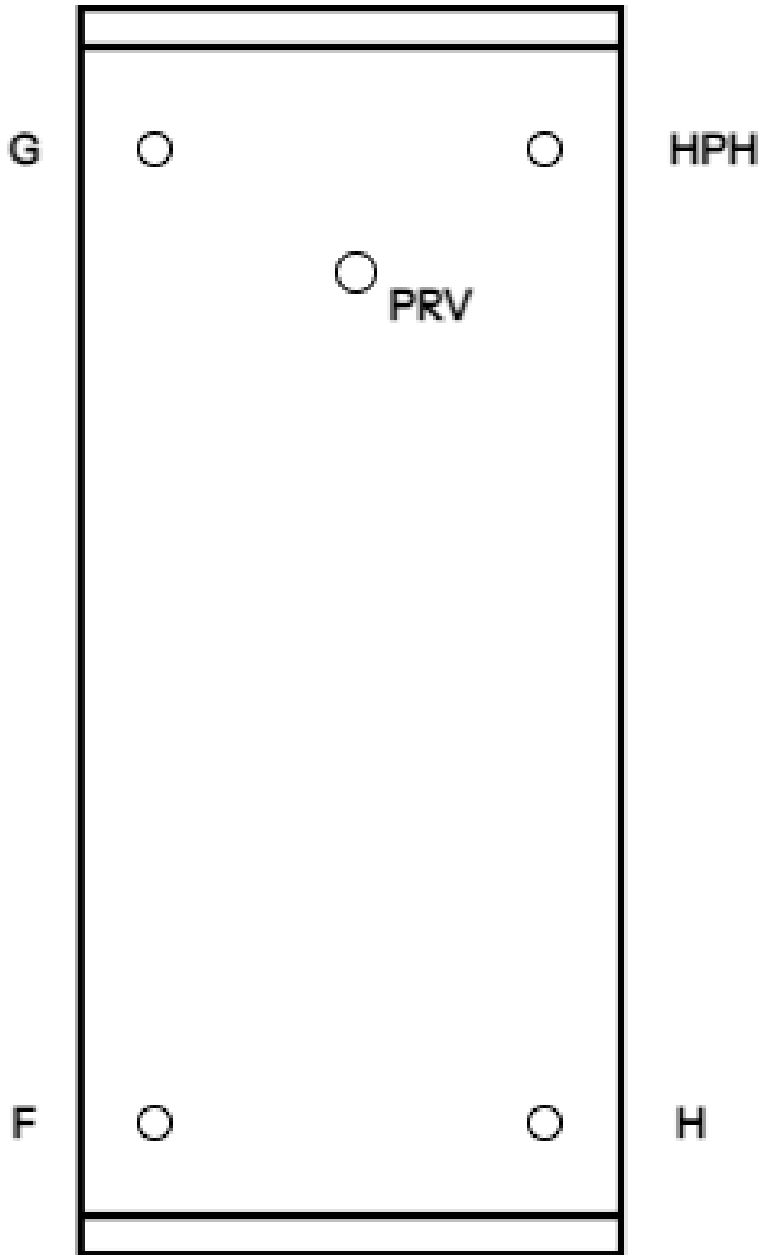

	83 Gal	119 Gal
F: Air Handler Return	3/4" NPT	1-1/2" NPT
G: Hot Water Outlet	3/4" NPT	1-1/2" NPT
HPH: Hot Water Return from HP	3/4" NPT	3/4" NPT
H: Cold Water Inlet/Return to Heat Pump	3/4" NPT	3/4" NPT
PRV: Pressure Relief Valve	Valve Provided	Valve Provided

 **Note**

NOTE: Dielectric unions or 6” brass couplings are required at all 119 Gal tank connections.
Heat Traps (see [Plumbing System Diagram](#)) required for top connections.

Harvest Pod

Location

The Pod is required to be installed in weather-protected space at a minimum, such as a garage, basement, crawlspace, indoor closet, or outdoor closet where there is no risk of freezing.

Caution

WARNING: The Pod is not intended to be fully waterproof. Install in dry location and take care while modifying plumbing near Pod so as not to damage the Pod's electrical components with water.

WARNING: Always put Pod cover on when soldering to avoid solder splatter on electronic components

Recommended to be installed as close to tank as reasonable, and can be:

- Wall-hung near tank, or
- above the tank in closet

Dimensions and Clearances

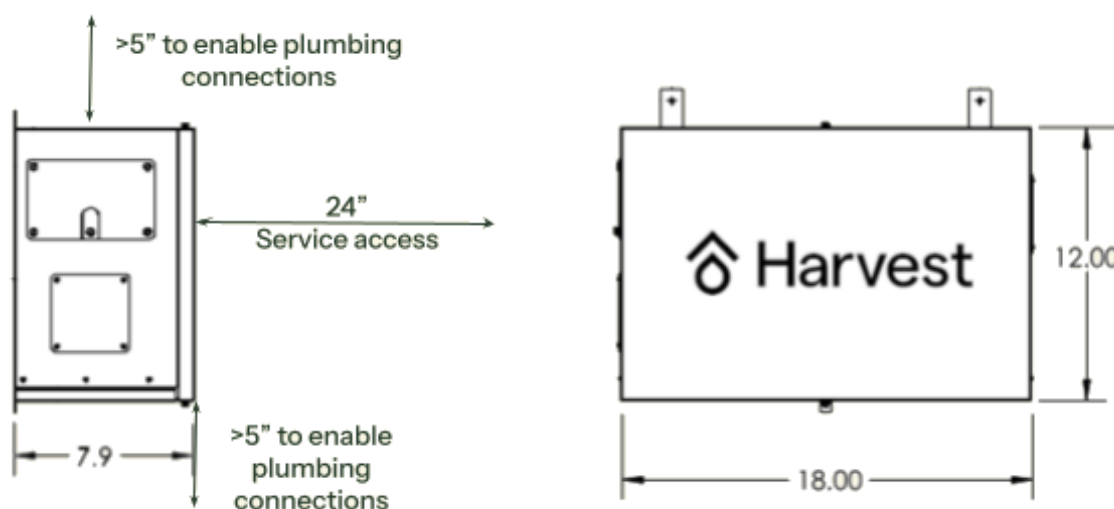

Minimum 24" of clearance is required in front of pod for wiring installation and future service access.

Mounting

Mount to studs or sturdy surface with screws using provided mounting holes.

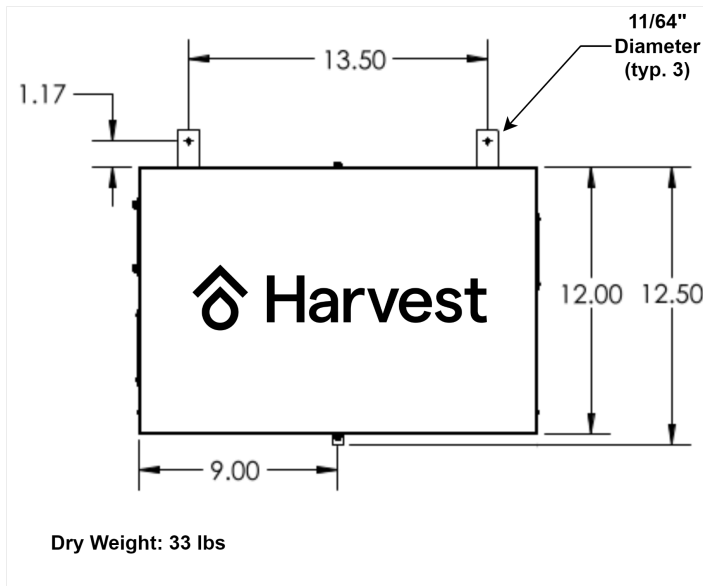

Power

The pod will require a 120V power outlet for the included 24 VDC power supply (refer to [Low Voltage Wiring Diagram](#)).

Internet

The Harvest Pod will require either an Ethernet or WiFi connection. This enables over-the-air updates, access to weather forecasts, and remote monitoring of the system. Ethernet is the most robust and therefore recommended option. See [Start Up](#) for more info.

Plumbing Connections

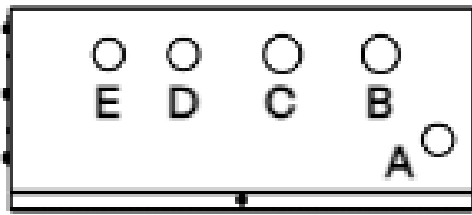

	Size
A: Heat Pump Cold	1/2" NPT
B: Utility In	3/4" NPT
C: DHW Hot	3/4" NPT
D: Air Handler Supply	1/2" NPT
E: Air Handler Return	1/2" NPT
F: Cold Water to Tank	3/4" NPT
G: Hot from Tank	3/4" NPT
H: AHU Return to Tank	1/2" NPT

Radiant Heat Exchanger

Location

Piping to the hydronic coil from the Pod must be < 100 ft in equivalent length, with < 35 ft of lift.

Configuration

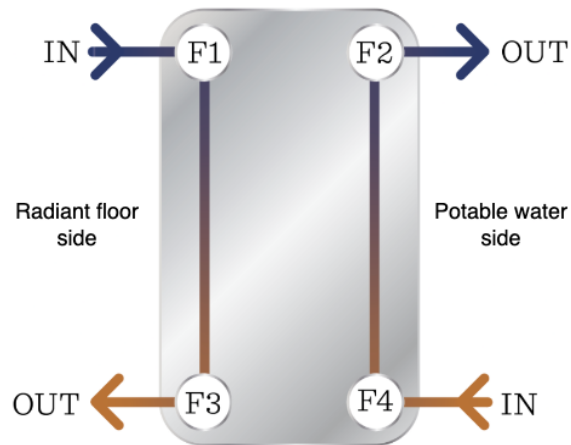

- Ensure the heat exchanger is plumbed in a counterflow direction. The hot water flowing in from the potable plumbing loop will be on the same end of the heat exchanger as the hot water flowing out of the heat exchanger into the radiant floor loop.
- The heat exchanger can be installed vertically or horizontally

Integrating DHW Recirculation

On-demand DHW recirculation can work with a Harvest Thermal Battery system.

As shown in the [Plumbing System Diagram](#), a DHW recirculation pump must be connected “outside” of the Harvest Pod Thermal Battery system, between the utility cold water coming into the Pod (B) and the DHW exiting the Pod (C).

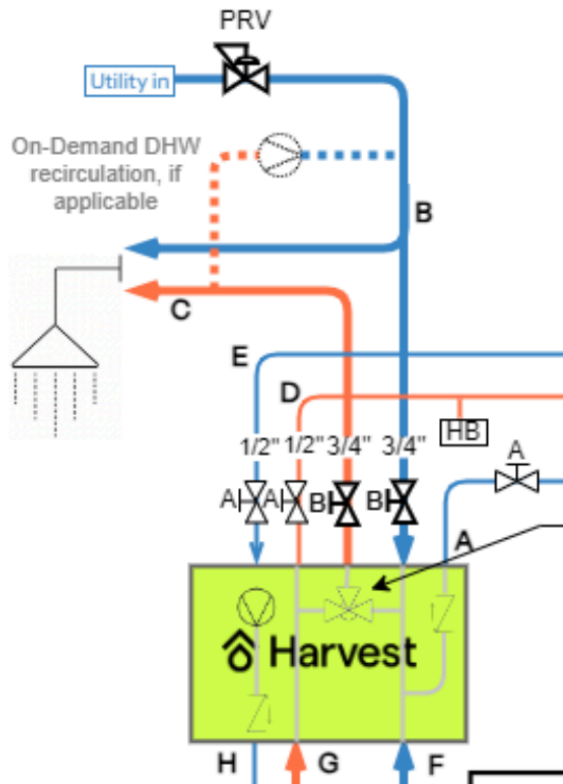

Danger

WARNING: Always-On and Timer-Based DHW recirculation systems will destratify the storage tank and cripple the Thermal Battery system operation. ONLY use On-Demand DHW recirculation.

Here are some examples of on-demand DHW recirculation systems that work well with the Harvest Thermal Battery System.

For homes with a dedicated return line:

[Smart Aquastat Control 32](#), from Lerdian Dynamics, is a controller that will sense when a DHW call is made and turn on the pump. This means that a short use of any hot water tap is equivalent

to pushing a button to start the recirculation pump. Choose a recirculation pump that will move 2-4 gpm of water, so that once a hot water tap is initially turned on and off, water is recirculated as quickly as possible.

Smart Aquastat 32 Controller Settings

- Temperature Range: 80F - 90F. When the temperature is below 80F at the recirculation pump, the pump will turn on when triggered by the flow sensor, and will then turn off when the temperature reaches 90F at the recirculation pump.
- Max Pump Run Time: 3 min. It rarely takes longer than 3 minutes to circulate water in the dedicated return line, and this setting helps to minimize any issues if the temperature sensor is not reading accurately.

Instructions on how to reconfigure a Smart Recirculation Control 32 as a Smart Aquastat Control 32

- The firmware can be updated via the smartphone app
 - Start the app and connect to your controller
 - There is a Firmware menu button at the bottom right of the app.
 - There is an option on the firmware update screen to “Show All Firmware Versions” which will display the firmware from our entire product line.
 - Select the Smart Aquastat 32 firmware and install that.
- One of the temperature sensors needs to be disconnected.
 - There are two temperature sensors plugged into an RJ-14 splitter.



Disconnect the temperature sensor that is on the plumbing line C, coming out of the Pod.

The remaining temperature sensor should be on the dedicated return line right next to the recirculation pump.

- Follow the instructions above to apply the right Settings for the Smart Aquastat 32 Controller

For homes without a dedicated return line

The [Smart Thermostatic Control](#), from Leridian Dynamics, is good option for an on-demand recirculation pump which works with the included high flow cross-over valve kit which gets installed under a remote kitchen or bath fixture.

Plumbing

- [Single SANCO2 Plumbing Diagram](#)
- [Twin SANCO2 Plumbing Diagram](#)
- [Double-Tank Plumbing Diagram](#)

Single SANCO2 Plumbing Diagram

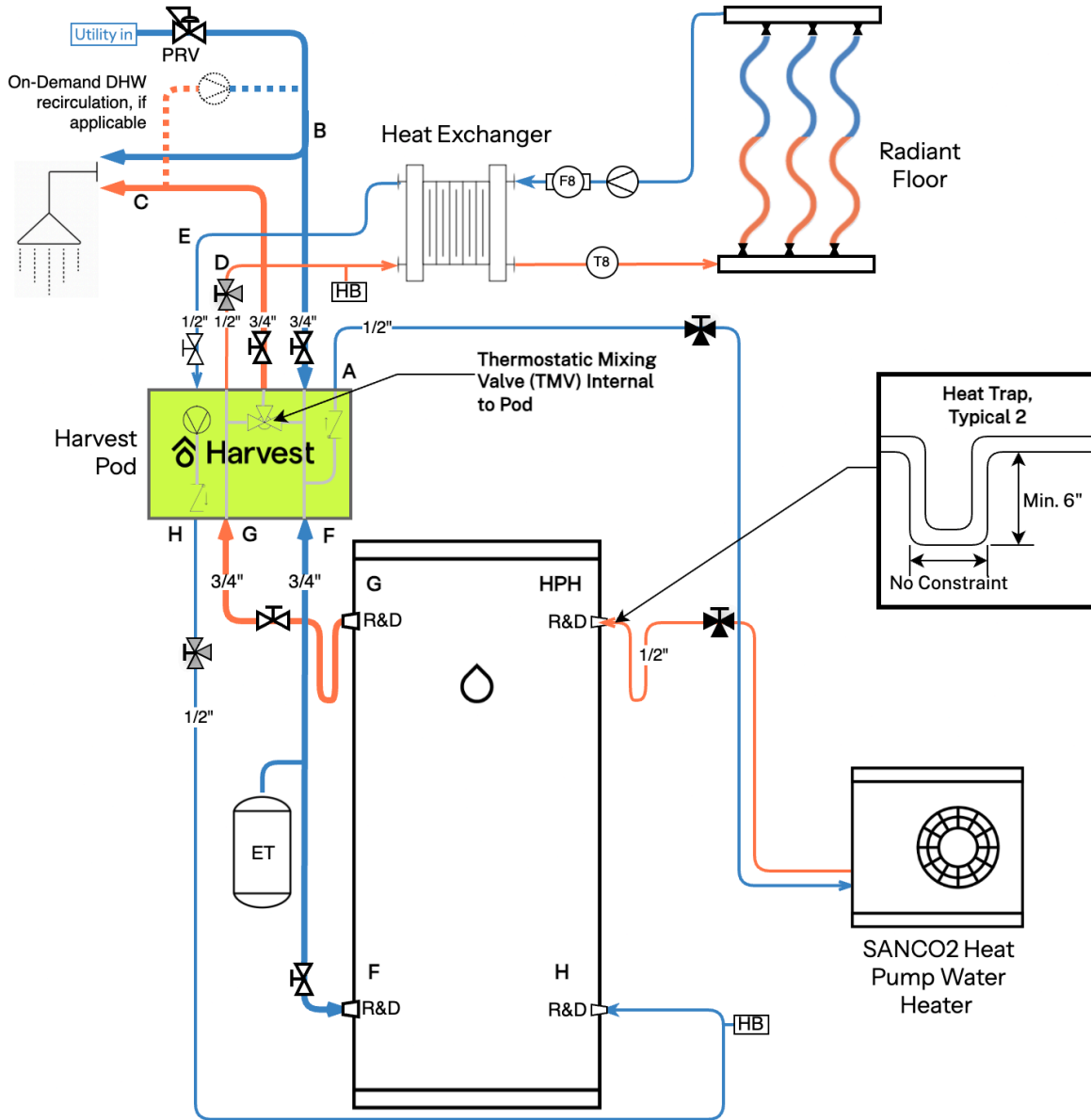

Legend			
	1/2" Ball Valve		R&D Reducer and Dielectric Union
	3/4" Ball Valve		R Reducer
	Harvest 1/2" Service Valve with drain (provided)		ET Expansion Tank
	SANCO2 1/2" Service Valve with drain		HB Hose Bibb
	PRV Pressure Regulating Valve		Supply Piping
			Return Piping
			F8 Visual Flow Meter (provided)
			T8 Temperature Sensor (provided)

Note

Only Harvest-provided fittings and 3rd party circulation pump are shown on the radiant floor loop. Follow best practices for remaining plumbing and fittings for the radiant floor loop.

Caution

Only install additional plumbing features, such as DHW recirculation pumps, on plumbing lines B and C.

Caution

WARNING: Maximum incoming pressure not to exceed 75 PSI with pressure reducing valve.

Caution

WARNING: Be sure to include all valves, meters, sensors and heat traps shown in the drawings in this manual. The system will not operate properly without these, and in some cases, may not operate safely.

Caution

WARNING: Before performing any plumbing work, ensure the Pod is completely powered off and the front cover is securely in place. Failure to do so may result in water damage to the Pod's electronics, which is **not covered under warranty**.

Note

NOTE: See [Harvest Radiant Tech Specs](#) for full plumbing schedule

See links for the:

[Plumbing Connections for the SANCO2 Heat Pump](#)

[Plumbing Connections for the Tank](#)

[Plumbing Connections for the Harvest Pod](#)

[Plumbing Connections for the Hydronic Coil](#)

Twin SANCO2 Plumbing Diagram

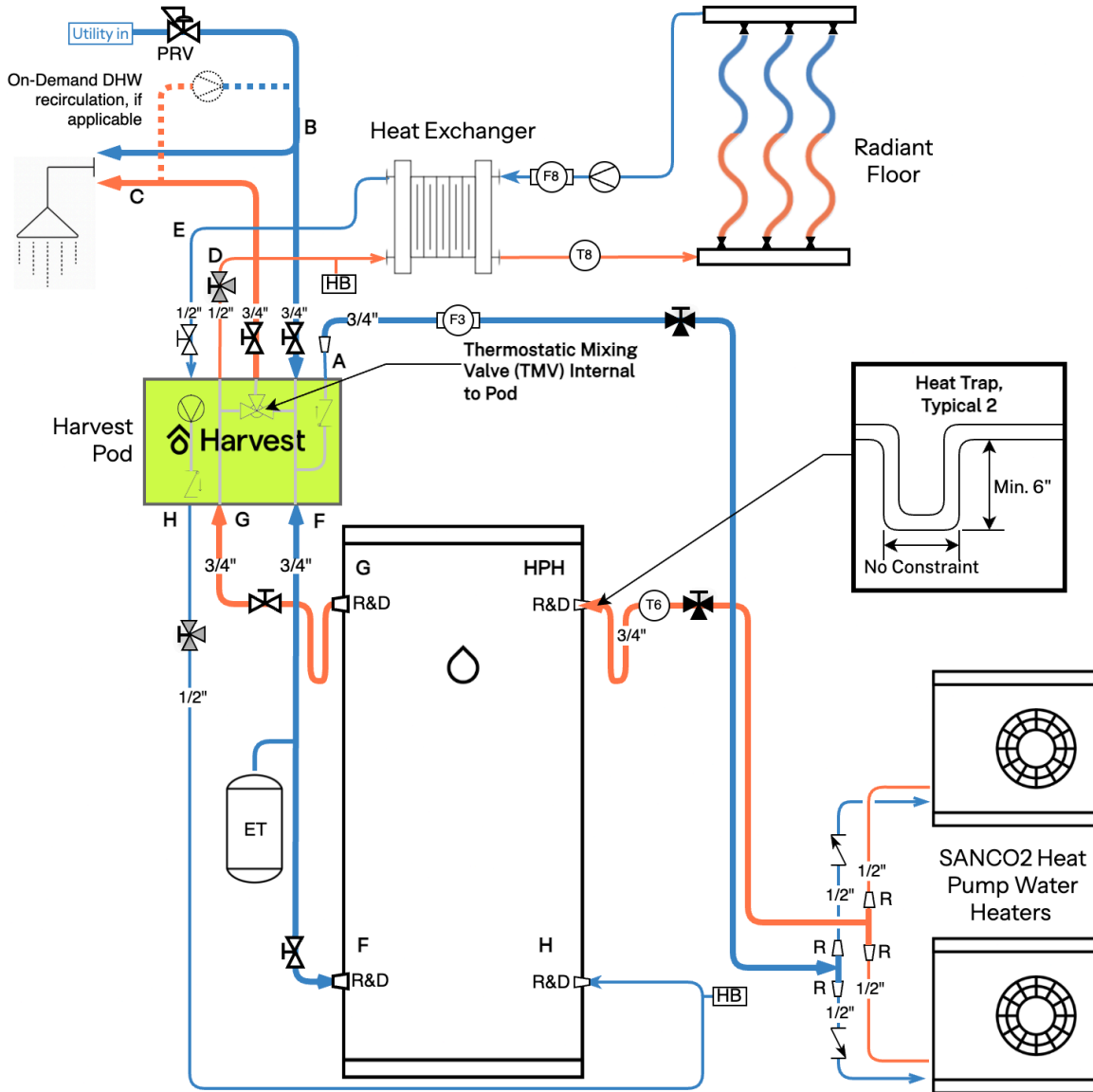

Legend			
	1/2" Ball Valve	R&D	Reducer and Dielectric Union
	3/4" Ball Valve	R	Reducer
	Harvest 1/2" Service Valve with drain (provided)	ET	Expansion Tank
	SANCO2 1/2" Service Valve with drain	HB	Hose Bibb
	Pressure Regulating Valve	F3	F3 Flow Meter (provided)
		T6	T6 Temperature Sensor (provided)
			1/2" Swing Check Valve (provided)
		T8	T8 Temperature Sensor (provided)
		F8	F8 Visual Flow Meter (provided)
			Supply Piping (Red line)
			Return Piping (Blue line)

A Twin HPWH system changes the plumbing only around the heat pumps.

- **Calculate line effective length:** add up the length of 1/2" and 3/4" pipe from heat pump to Pod/heat pumps, and add 1/2 ft per short-radius elbow (large-radius elbows don't count): this should be **60' or less**. $L_{Effective}(ft) = L_{3/4} + 0.5 * (qty\ 3/4" \text{ elbows}) + L_{1/2} + 0.5 * (qty\ 1/2" \text{ elbows})$
- The effective lengths for each heat pump should be maintained within 10% of each other.
- Install *swing* check valves on cold side of each 1/2" heat pump line
- Install flow meter near pod connection A (on HP cold line) on the common 3/4" line, oriented to measure flow out of the pod.
- Install thermistor T6 on the common heat pump hot line
 - Attach thermistor to pipe using foam tape or tie down with zip tie
 - Insulate the thermistor generously to ensure it is not affected by air temperature

Double-Tank Plumbing Diagram

⚠ Caution

WARNING: Failure to minimize fittings and bends of the “bridge pipe” between the primary and secondary tank may significantly impact system performance.



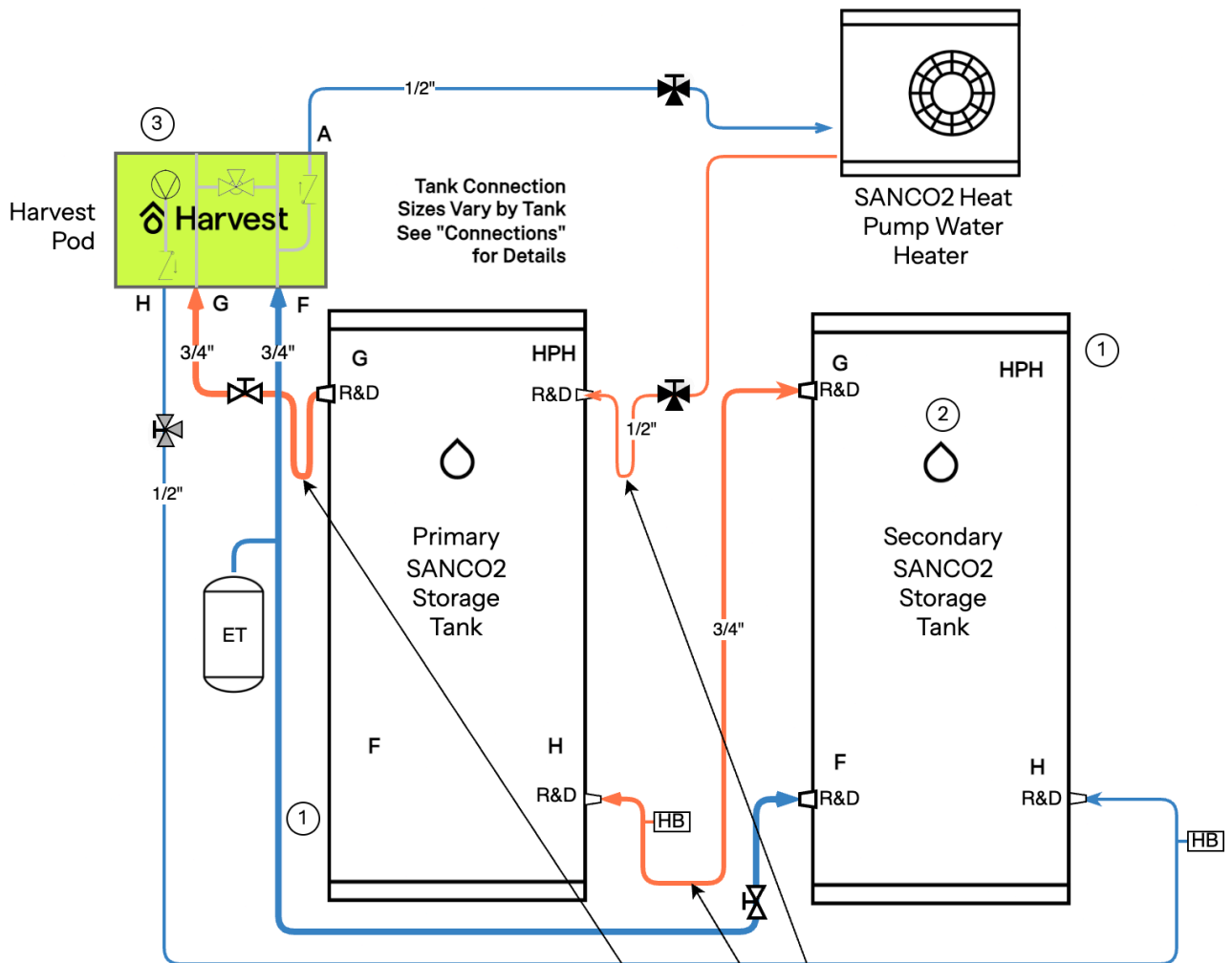





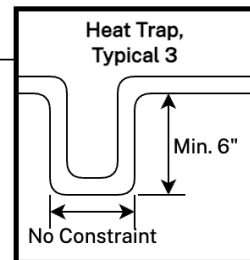

It is **HIGHLY** recommended to use either a single piece of 3/4” PEX, or 3/4” copper with a long radius elbows to minimize the pressure drop along this bridge pipe.



Notes:

1. Cap unused tank connection
2. No TPV valve is needed on the secondary tank if no valves are placed on the bridge pipe between H of the primary tank and G on the secondary tank
3. Heating loop, utility in, and DHW plumbing not shown for clarity. Refer to overall plumbing diagram



Legend					
	1/2" Ball Valve	 R&D	Reducer and Dielectric Union	 Supply Piping	 Return Piping
	3/4" Ball Valve	 R	Reducer		
	Harvest 1/2" Service Valve with drain (provided)	 ET	Expansion Tank		
	SANCO2 1/2" Service Valve with drain	 HB	Hose Bibb		
	PRV Pressure Regulating Valve				

Insulation

Note

NOTE: Proper insulation is required to achieve good system performance

Tank

- 1+” polyiso (min. R-6) insulation required under tank
- Insulate tank with min. R-8 insulation around sides and top of tank.
- Insulate pressure relief valve with min. R-6 insulation.

Pipes

- All pipes, excluding the Cold Supply pipe (line B), are required to be insulated with minimum 1” (R-6) insulation.
- Include insulation on all valves and couplings.
- Pipes should be clamped outside of the insulation.

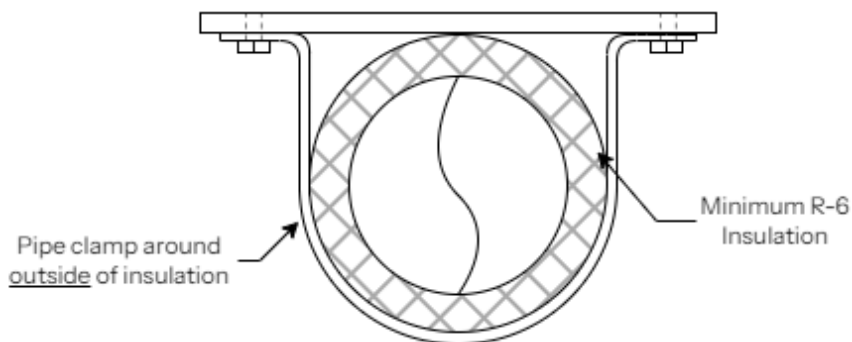

SANCO2

- All requirements above apply to SANCO2 piping.
- Piping inside of SANCO2 cover should also be insulated.
- Ensure all outside piping is weatherized.

Cold Climate Installations

Water will circulate to the SANCO2 heat pump, which is mounted outside. It's important to take appropriate actions for cold-climate installations to mitigate the risk of water freezing in the pipes and the heat pump. Failure to do so could lead to damage and operational issues.

SANCO2 Freeze Protection Approaches

SANCO2 provides the following approaches to mitigate water freezing in the heat pump. The SANCO2 documentation of these approaches can be found [here](#):

- Minimize the length of piping outside
- Automated freeze protection control program built into the heat pump
- Heat tape on exterior pipework
- Automated freeze protection via drain valves when there is a power outage
- Manual freeze protection when there is a power outage.

Submittal sheets for the recommended heat tape (FG2-6L or FG2-12L) and drain valves (ECO-FPVKT-SMTW) can be found [here](#).

Cold Climate sensors

Note

A Sensor kit is required for installation

In a cold climate, directly measuring the heat output of the SANCO2 enables better control of the state of charge of the thermal battery.

Install and wire the flow meter (F3) and the temperature sensor (T6), provided as part of the sensor kit, as shown in the figure below.

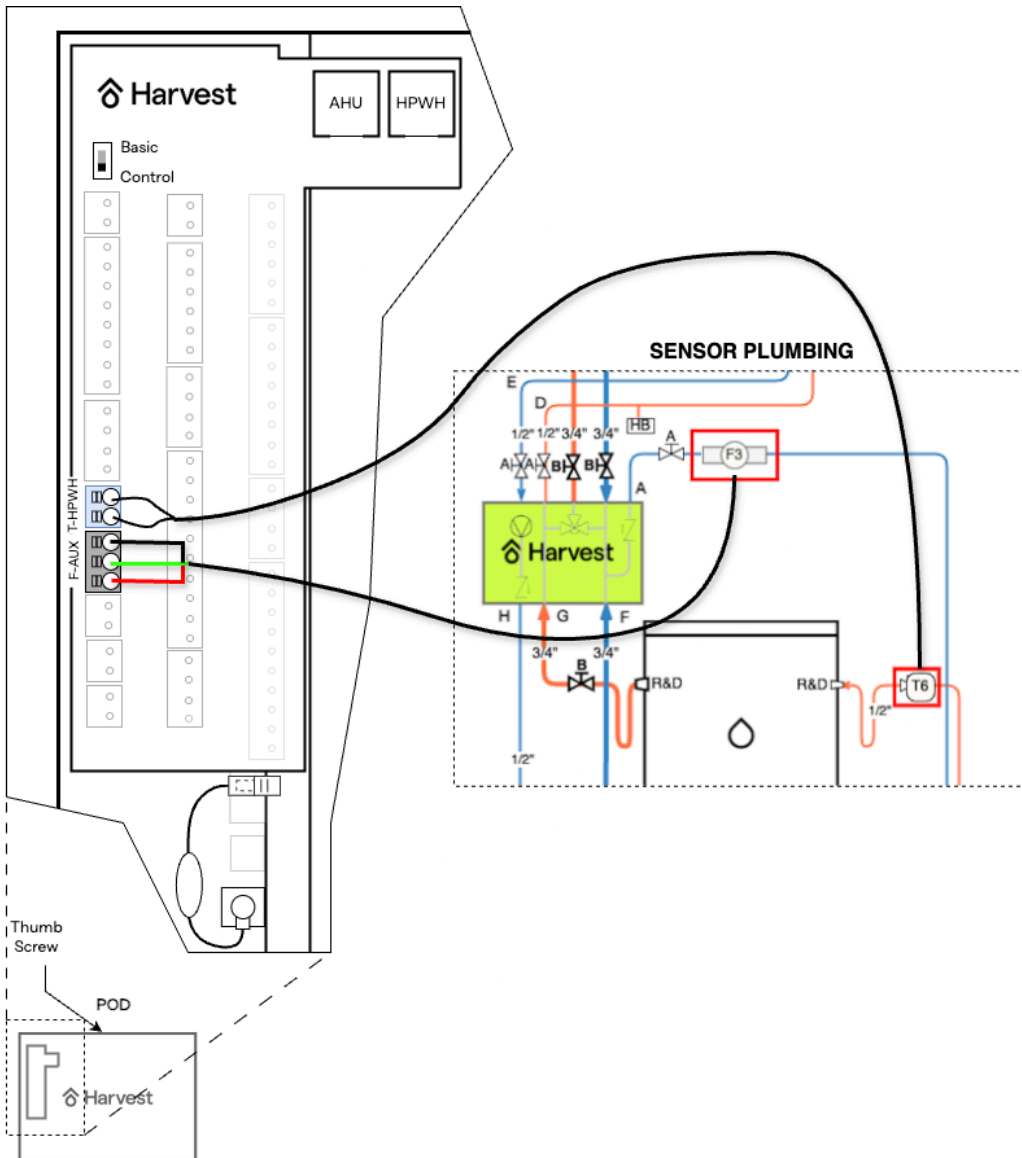

⚠ Caution

The flow meter has a flow direction marked. It should point towards the SANCO2 heat pump.

ℹ Note

Use tstat wire (18/x) to extend the thermistor or flow meter wires if needed

Using an Electric Tank Booster

A tank booster may be added to the Harvest system to help maintain warm water in the hydronic system if the outdoor temperature drops below -25°F , at which point the SANCO2 heat pump will no longer be able to produce hot water.

In addition, an electric tank booster can be used to extend the hydronic storage capacity of a Harvest system. This can be beneficial to meet the home heating load if the capacity of the auxiliary DX heat pump drops due to low outdoor temperatures.

The booster will turn on when tank thermal storage is depleted (specifically, whenever flow > 0.30 gpm and inlet temperature < 115°F).

There are two primary choices for an electric tank booster:

- RHEEM RTEX-AB7 7.2 kW booster - 30A breaker and 50°F temperature rise at 1gpm
- RHEEM RTEX-11 11 kW booster - 50A breaker, and a 50°F temperature rise at 1.5gpm

Note

A Booster kit is required for installation

Plumbing Diagram

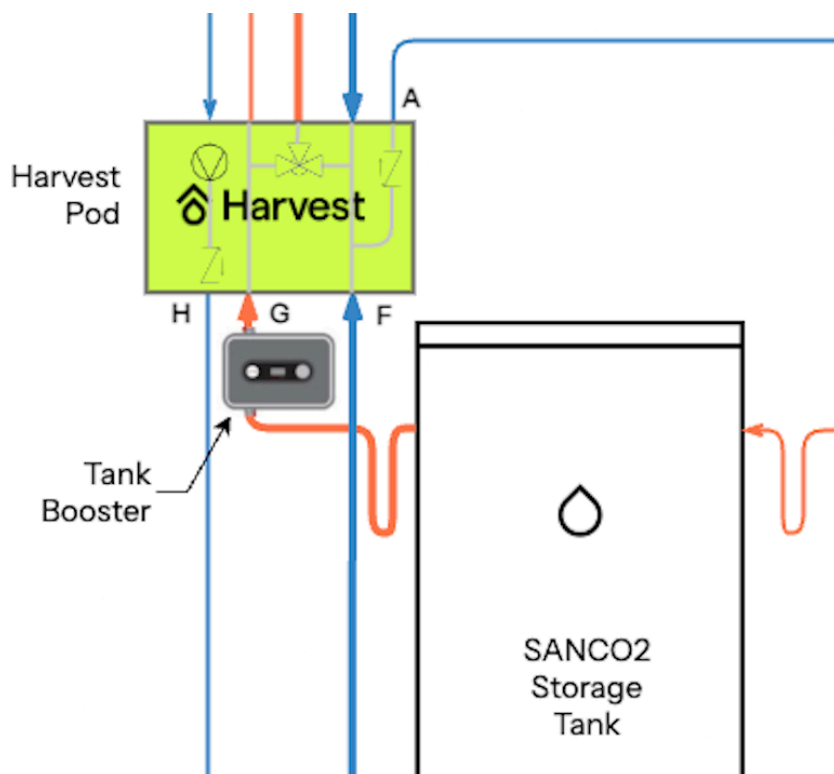

- 14 in. of straight pipe clearance is required for installation below the Harvest Thermal Pod.
- 6 in. of clearance is required on the front and sides of the booster for service maintenance.

⚠ Danger

Make sure there are no leaks. FAILURE TO DO THIS BEFORE ENERGIZING THE BOOSTER CAN CAUSE PERMANENT DAMAGE.

High Voltage Electrical Wiring

⚠ Danger

ELECTRICAL SHOCK HAZARD - CONFIRM ALL CIRCUITS ARE DE-ENERGIZED BEFORE PERFORMING ANY WIRING ACTIVITY.

- 1 Install a new disconnect box connected to the main panel and located near the booster
- 2 Connect booster L1, L2, G terminals to the disconnect box. Do not use the T1 or T2 terminals.

If you are using the RTEX-AB7 booster, the Harvest Pod can provide additional control of when this unit is powered by installing the RIB24Z relay provided as part of the Booster install kit:

- Splice L1 with one of the RIB24Z relay's blue wires (blue wires are the NC relay connections).
- Connect the other RIB24Z relay blue wire to the disconnect.
- Do not use the orange wires (NO relay connection)

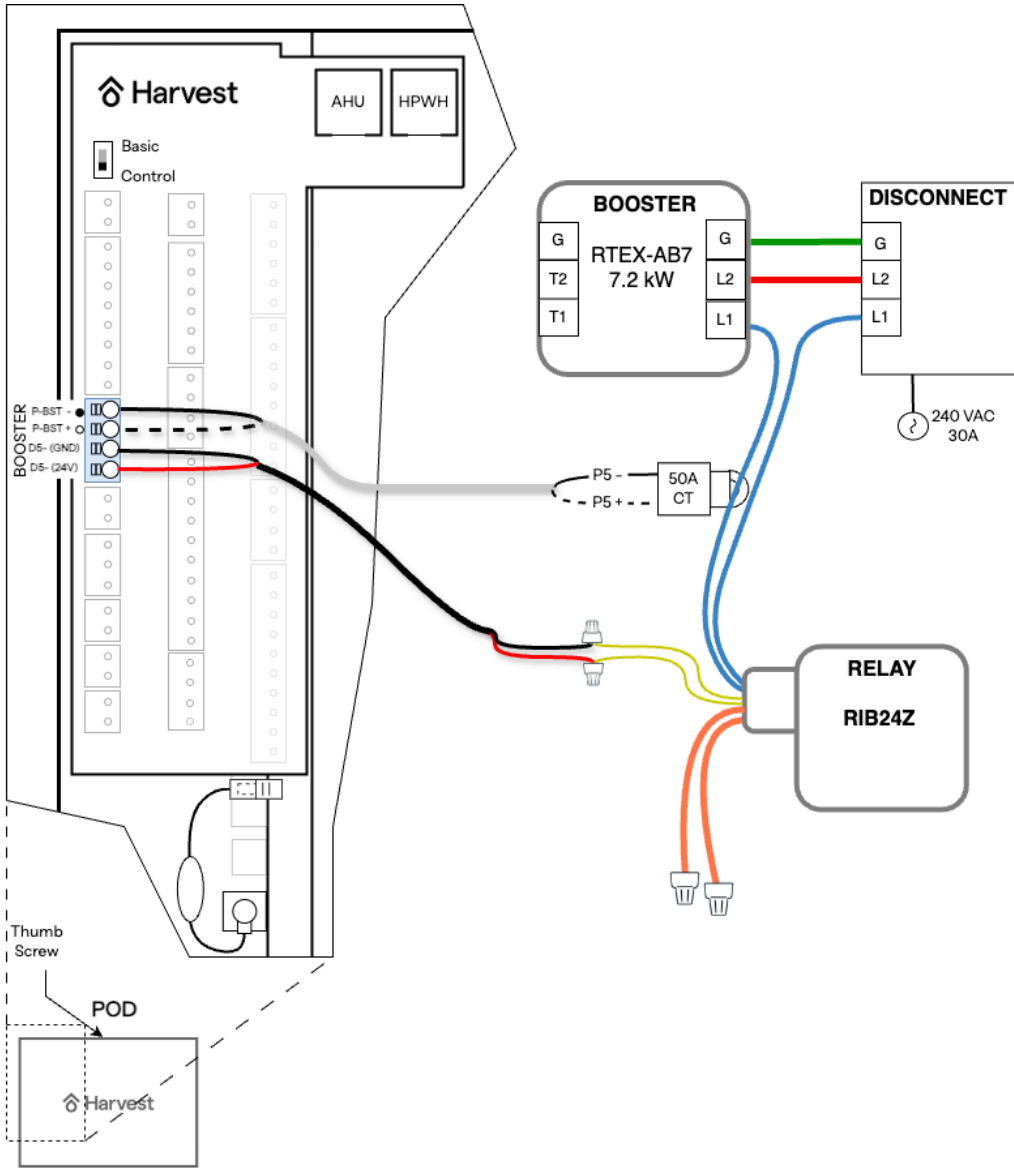

RHEEM RTEX-AB7 7.2 kW booster wiring

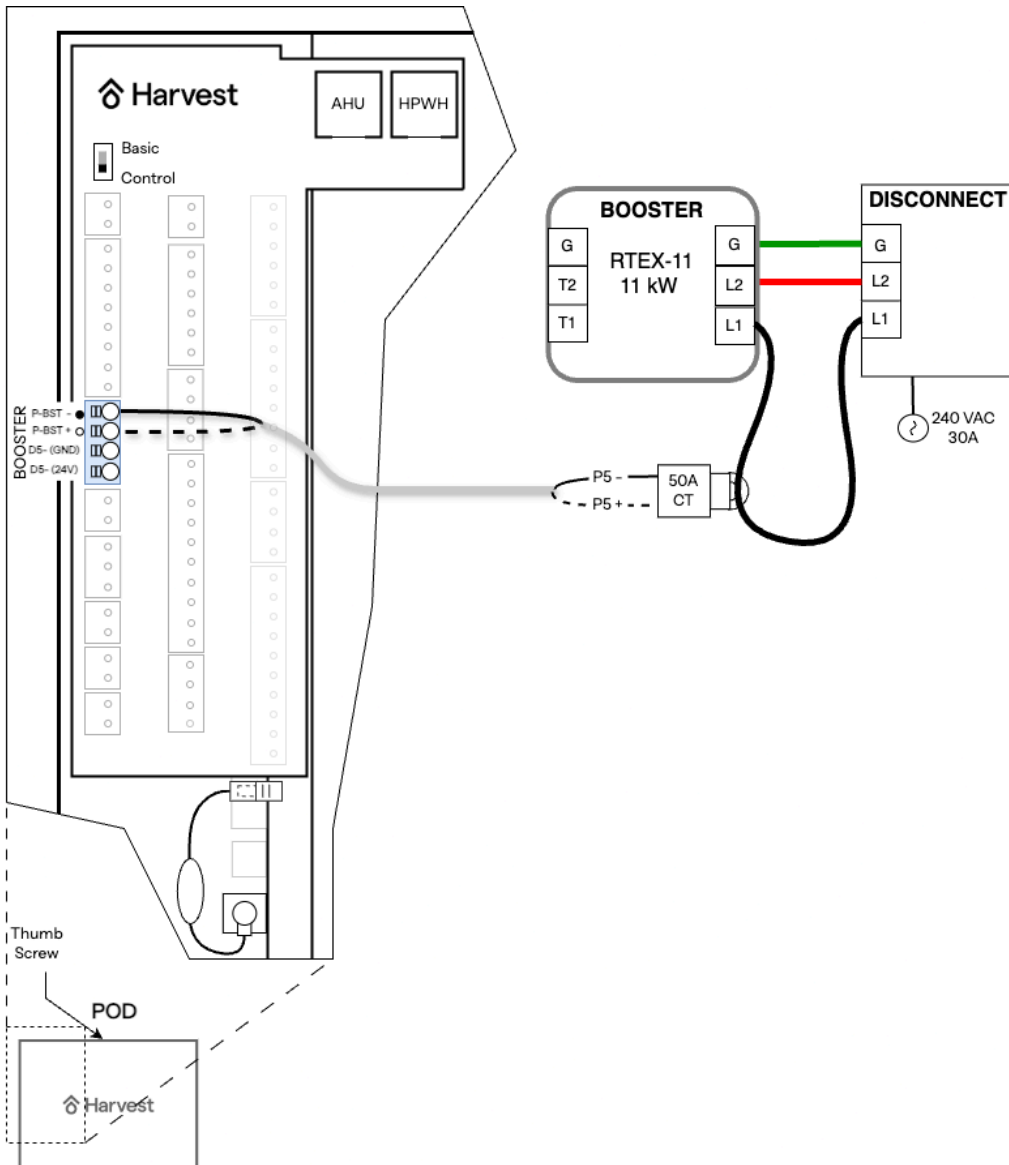

RHEEM RTEX-11 11kW booster

Low Voltage Electrical Wiring

- 1 Install the 50A CT, provided in the Harvest Booster Install kit around the wire going to the L1 terminal.
- 2 Using 18-4 AWG wire, follow the figure below to connect the CT to the Pod

If you are using the RTEX-AB7 booster, the Harvest Pod can provide additional control of when this unit is powered by wiring the RIB24Z relay as follows:

- Use the other two wires from the 18-4 AWG wire to connect the RIB24Z relay yellow control wires to the Pod.

Booster Setup

Energize the booster and program it with the settings below.

- To cycle through menu options or adjust a setting, rotate the knob on the front of the booster.
- To enter a menu option press the control knob.

Setting	Value
ACTIVATE	115
MAX TEMP	130
VACATION	No
ECO MODE	No

Caution

Don't forget to set the cold climate dip switch (STD/CLD) inside the Harvest Pod when doing the low-voltage wiring.

Low Voltage Wiring

- **SANCO2 Low Voltage Wiring**
 - Single SANCO2 Wiring
 - Twin-SANCO2 Wiring
- **Low Voltage Wiring Diagram**
- **Twin-SANCO2 Heat Output Sensor Wiring**

SANCO2 Low Voltage Wiring

Note

The Harvest Install kit includes a wiring harness to connect the Cat5 cable from the Pod to the SANCO2 Heat pump.

Single SANCO2 Wiring

Twin-SANCO2 Wiring

Single SANCO2 Wiring

Harvest wiring harness connections inside the signal box of the SANCO2

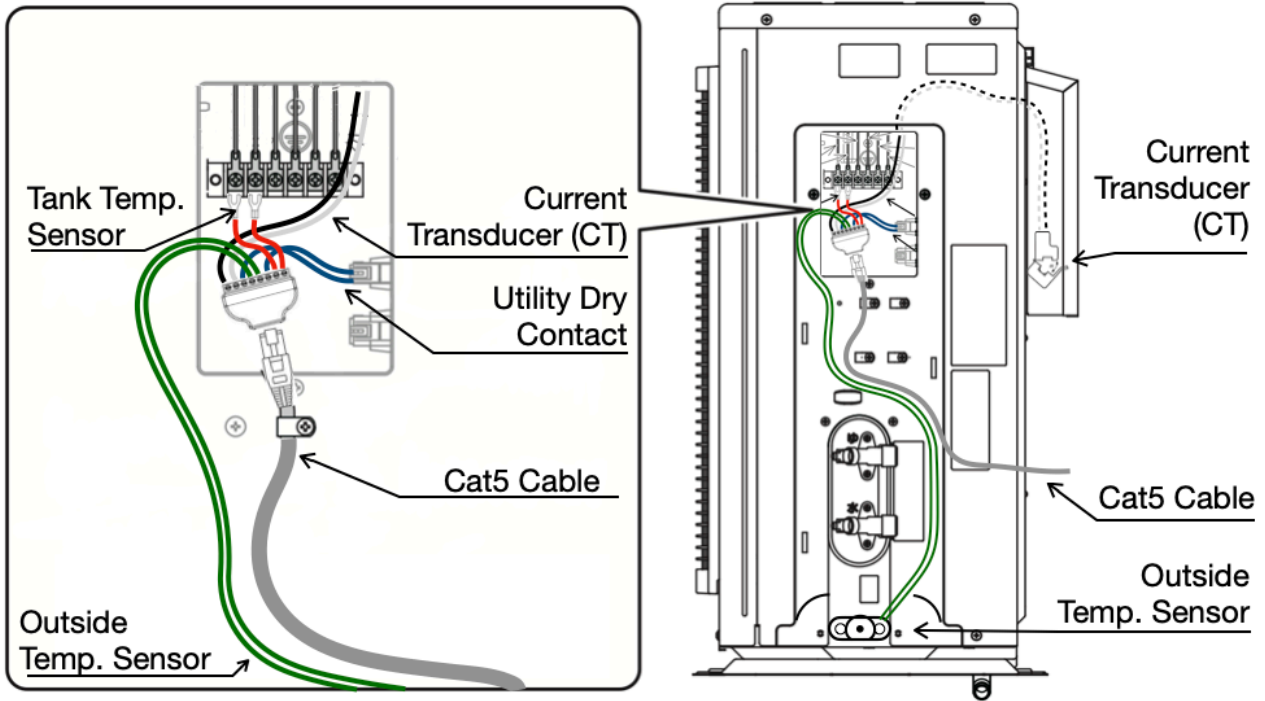

Replace the existing plate directly below the plumbing fixtures of the SANCO2 heat pump with the Outdoor Temperature Sensor plate that comes connected to the wiring harness. (see the video below for a cold climate mounting option)

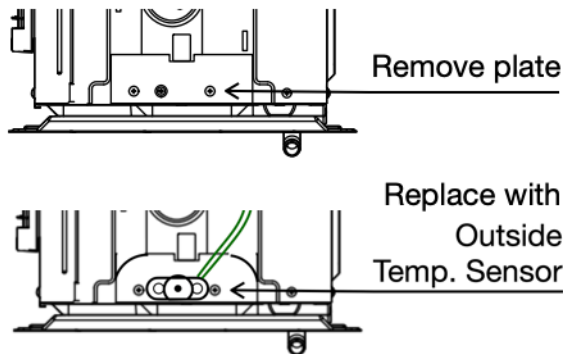

SANCO2 Gen5

Current Transducer inside the power box

The current transducer is clipped around **either** the L1 or L2 power line. The CT leads can be threaded through the inside of the SANCO2 to enter the signal box, and reconnected to the wiring harness.

Note

The polarity of the CT leads matters. The **black** CT lead connects to **pin 8** of the wiring harness.

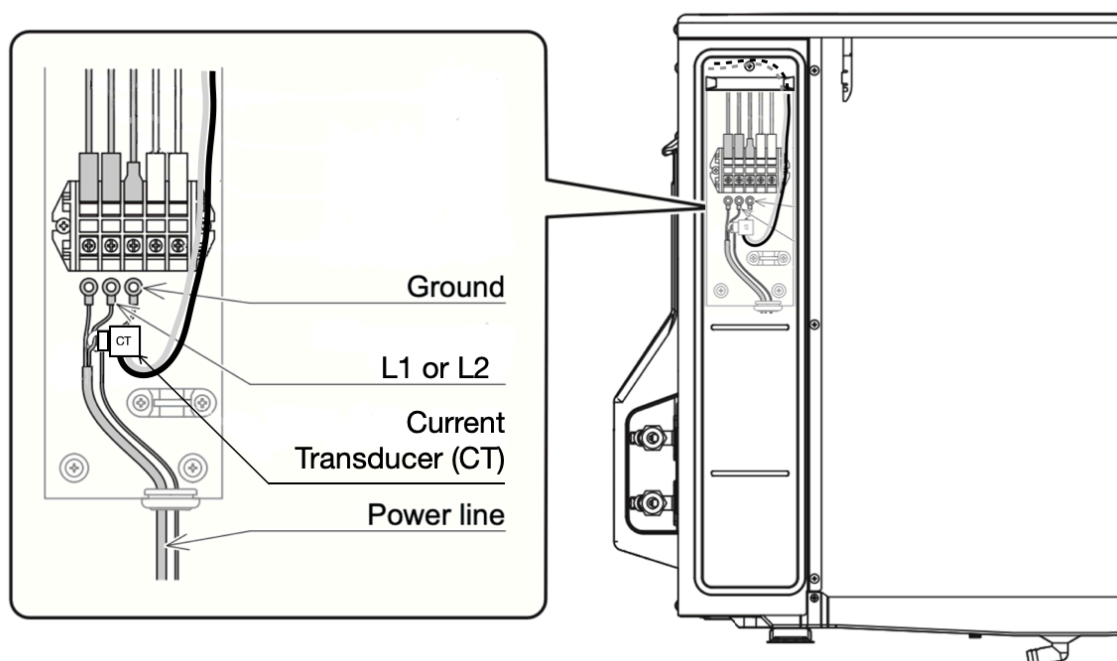

Background Source: SANCO2 GS4 Installation Manual

Note

NOTE: see [Powering the SANCO2](#) documentation for high voltage wiring.

Harvest OPEN: Wiring the SANC02

Harvest



Wiring the SANC02 HP



Watch on  YouTube

SPLIT SYSTEM HEAT PUMP WATER HEATER
POMPE & CHAUFFE CHAUFFE EAU
Model & Number 054-454HC
Voltage/Frequency 208/230V-1PH-60HZ
4.5kW
Capacity/Capacité
Fan Motor / Moteur de Ventilateur MOC 0.5A 30W
Water pump / Pompe à eau MOC 5.0A
Compressor / Compresseur 7.5A
MCA
Max Fuses / Circuit Breaker 15A
Fuses / Circuit Breaker
Refrigerant/R410A 25.0oz/710g
Refrigerant/R410A
Design Pressure / High/Press 1740Psi
Low/Press 1740Psi
Max Hot Water Temperature / Max Température de l'eau d'usage 38°C
Max Temperature of L. Entry
2009-08-11



Twin-SANCO2 Wiring

Harvest wiring harness connections inside the signal box of the primary SANCO2 heat pump

Follow the diagram for the [Single SANCO2 Wiring](#) setup, except for the 20 A CT.

Current Transducer inside the electrical subpanel box

- 1** Install the 20A CT on either the L1 or L2 incoming 30A power wires within the subpanel. This will require extending the length of the CT wires which can be done with 18/2 thermostat wire.
- 2** Install current sensing switch (RIBXGA Relay) within electrical subpanel on **one** 15A power wire powering the primary SANCO2 heat pump.
- 3** Cut the dry contact loop (white wire) inside the signal box of the secondary heat pump, and connect up to the current sensing switch. This will require extending the length of the current sensing switch, which can be done with 18/2 thermostat wire.
- 4** Connect the thermistor load assembly (7.5k ohm resistor) to the “temperature” terminals within the secondary SANCO2’s signal box.

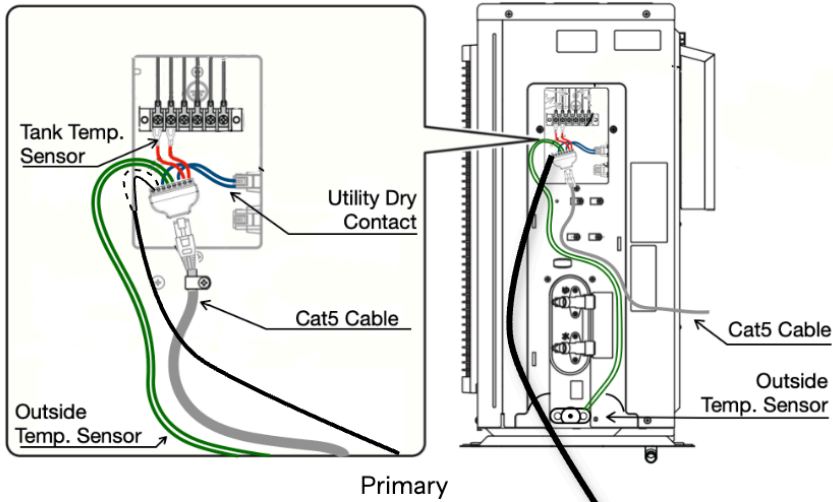

Primary

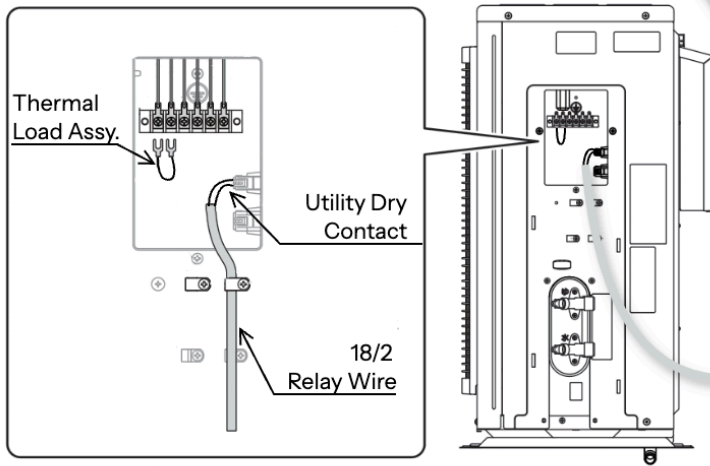
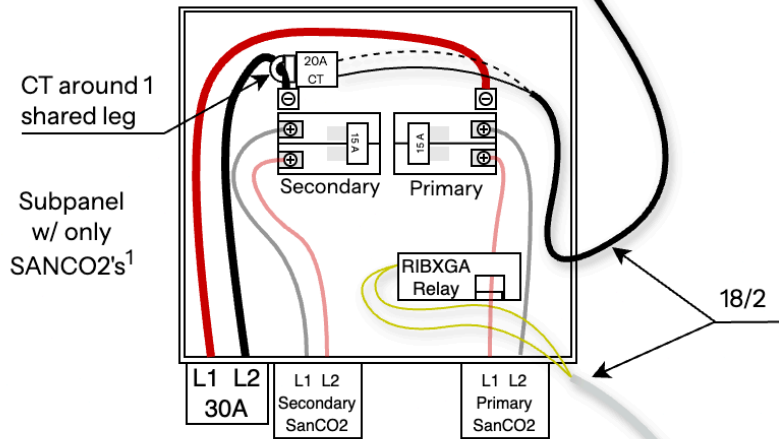

Secondary

Notes:

- 1. SANCO2 power wires to SANCO2's not shown for clarity. Refer to "Powering the SANCO2".

Low Voltage Wiring Diagram

⚠ Caution

WARNING: Do not power the Harvest Pod or 3rd Party Air Handler until all wiring is complete and correct. Wiring Harvest Pod incorrectly may damage the Pod.

- 1 Remove the thumb screws at the bottom and top of the pod to remove the front panel of the Pod and access the wiring connections.
- 2 To make internal wiring connections, push wires through the “hamster tube” from underside of the pod.

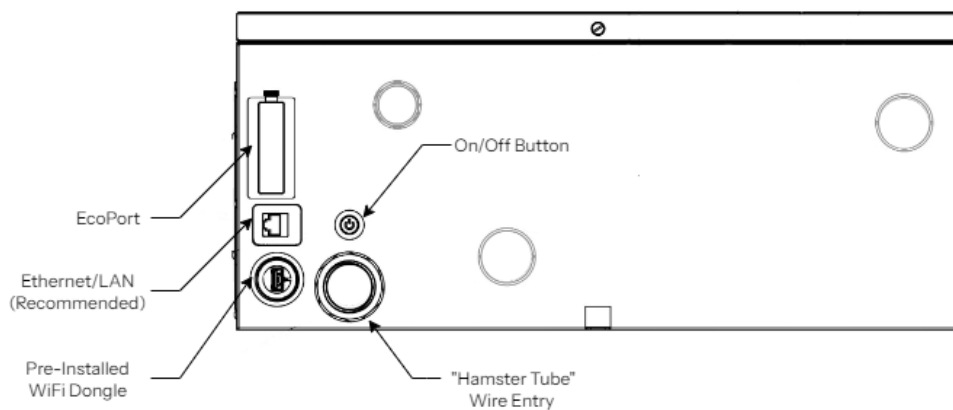

- 3 Wire the Pod according to the following diagram:

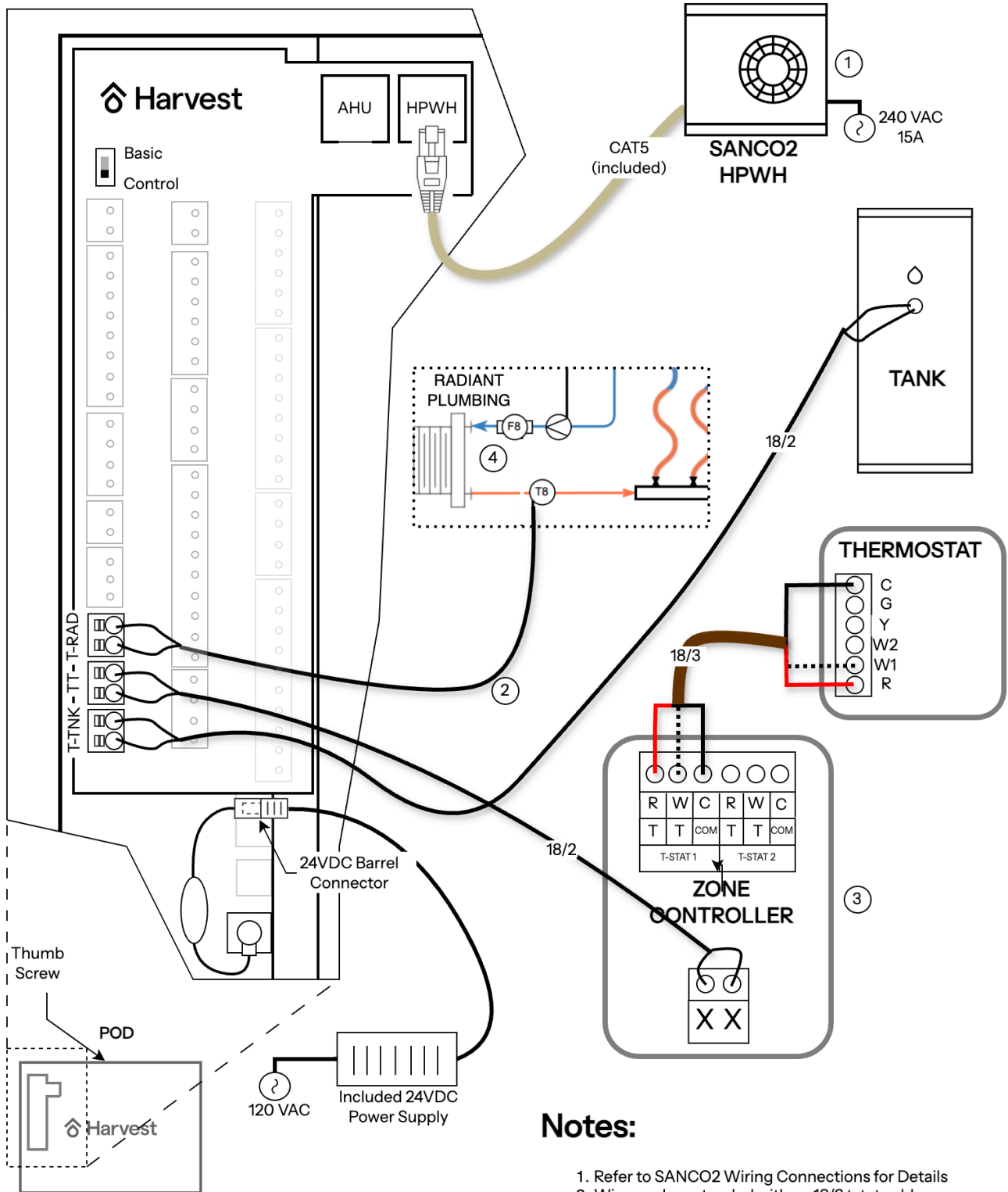

Notes:

1. Refer to SANCO2 Wiring Connections for Details
2. Wire can be extended with an 18/2 tstat cable
3. Zone controller wiring to secondary pump not shown. Follow manufacturer's guidelines
4. F8 is a visual flow meter

Twin-SANCO2 Heat Output Sensor Wiring

Note

A Twin-HPWH install kit is required for installation

Directly measuring the heat output of the combined heat pumps enables better control of the state of charge of the thermal battery.

Install and wire the flow meter (F3) and the temperature sensor (F6), provided as part of the kit, as shown in the figure below.

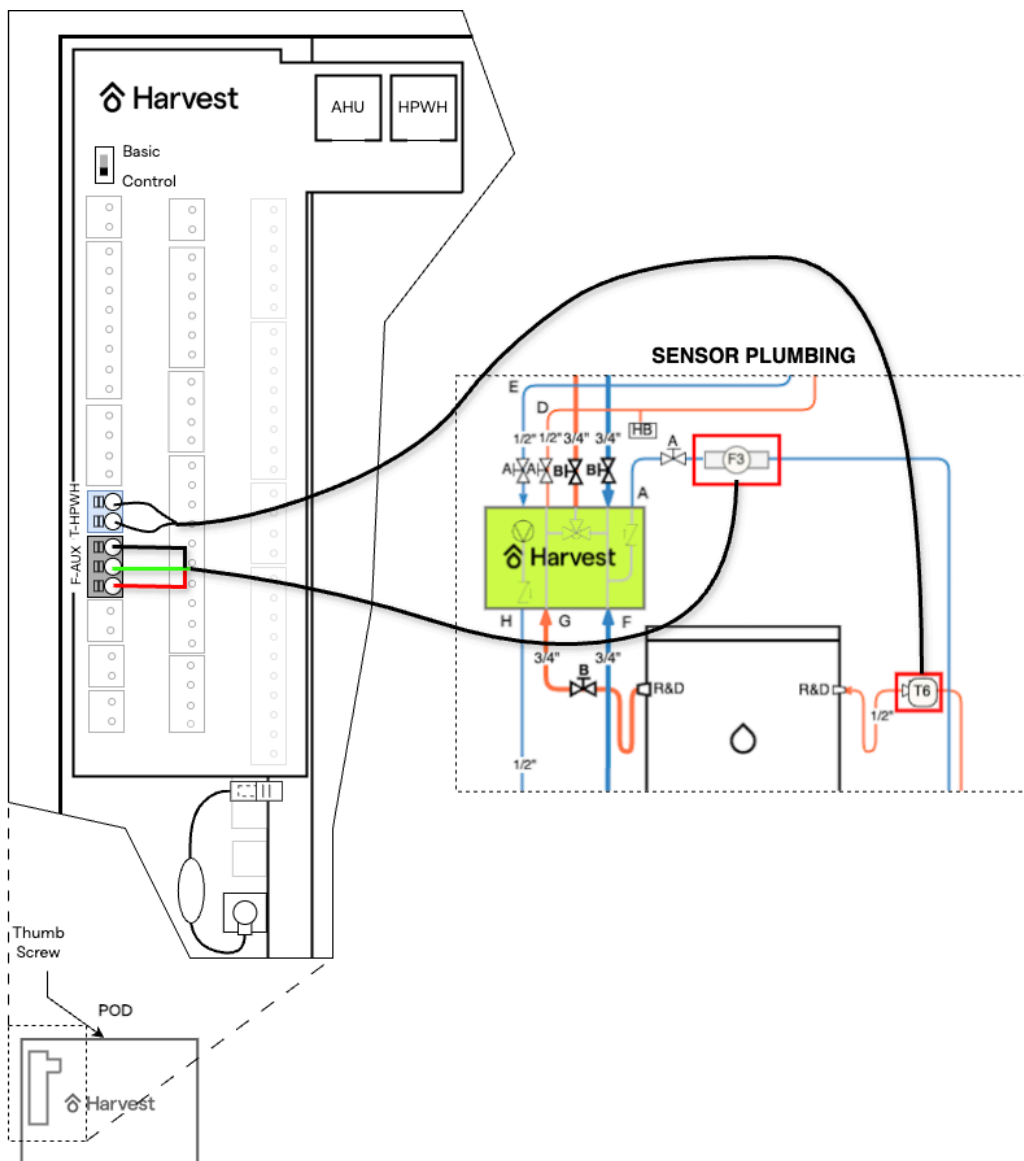

 **Caution**

The flow meter has a flow direction marked. It should point towards the HPWH.

 **Note**

Use tstat wire (18/x) to extend the thermistor or flow meter wires if needed

Start Up

- [Hydronic System Start Up](#)
- [Thermal Battery System Start Up](#)

Hydronic System Start Up

Caution

WARNING: Failure to properly bleed air from the SANCO2 heat pump, Pod, and hydronic coil may prevent the system from operating correctly and lead to damage to the SANCO2 Heat Pump.

Domestic Hot Water

- 1 Ensure all plumbing and wiring involving the SANCO2 and the Pod are correct and complete. Do **NOT** power the Harvest Pod at this time.
- 2 Fill the tank by opening valves on lines B and F (see [Plumbing System Diagram](#)).
- 3 Open PRV to allow air to exit the system. Leave open until water comes out of the relief valve.
- 4 Open the remaining valves (see [Plumbing System Diagram](#)).
- 5 Open the hot water faucets to bleed air from the house piping system. Close the hot water faucets after no air is seen in the water.
- 6 Open the three water bleed valves on the SANCO2 Heat Pump. Two are on the water connections, and the third is underneath the heat pump. Close the plugs after no air is seen in the water.
- 7 Power the SANCO2 outdoor unit.

Upon powering on, SANCO2 undergoes a 5-minute air bleed cycle, displays “12:00” on the screen, and begins to run.

 Tip

At this point, hot water will accumulate in the tank. It will take ~1 hour for the hot water tank to accumulate enough hot water for domestic hot water service to be usable.

Radiant Heat Exchanger

For the heat exchanger to operate, all air must be purged from the hydronic coil loop.

 Note

NOTE: A check valve inside the Pod means that purging the hydronic coil plumbing loop at the highest point of the system will not be effective.

- 1 Close the shut-off valve at the tank on line H (see [Plumbing System Diagram](#)).
- 2 Open the Hose Bib (HB) drain on line H to purge the hydronic coil and circulation pump. Continue purging until no air more air bubbles are visible in the water.
- 3 Close the drain and **re-open** the shut-off valve on line H.

Thermal Battery System Start Up

System Commissioning with the Harvest Tech App

- 1 Power on the Harvest Pod.
- 2 Connect your phone/tablet/laptop to the Harvest Pod's WiFi access point
 - o The network name (HarvestPodXXXX) and password can be found on the label on the bottom of the Pod
 - o Wait at least 5 minutes after powering the pod before attempting to access the Harvest Tech App.
- 3 Navigate to "<http://harvestpodXXXX.local>" using an internet browser, where "XXXX" is the same as the name of the network.

4

Configure the Internet Connection, and look for a green “Connected” indicator:

Harvest

Internet Customer Profile Setup Hardware

System Checks Air Handler Harvesting

Connect the Harvest Pod to the Internet

To get the most out of a Harvest Pod, it must be connected to the Internet. The connection lets it get the latest software updates to provide the most efficient operation, and to automatically notify Harvest Support when the system needs maintenance or adjustment.

Wired Network

Ethernet **Connected**
Connected via Ethernet

Nearby Wifi Networks

Rescan Wifi

Harvest Thermal
Speed: 130 Mbit/s Channel: 11
Signal: 85% Security: WPA2
Connect

Internet Status

The Pod is connected to the internet

Continue >

v2.1.0

5

Fill in the customer profile and time zone (password can be found on the label on the bottom of the pod):

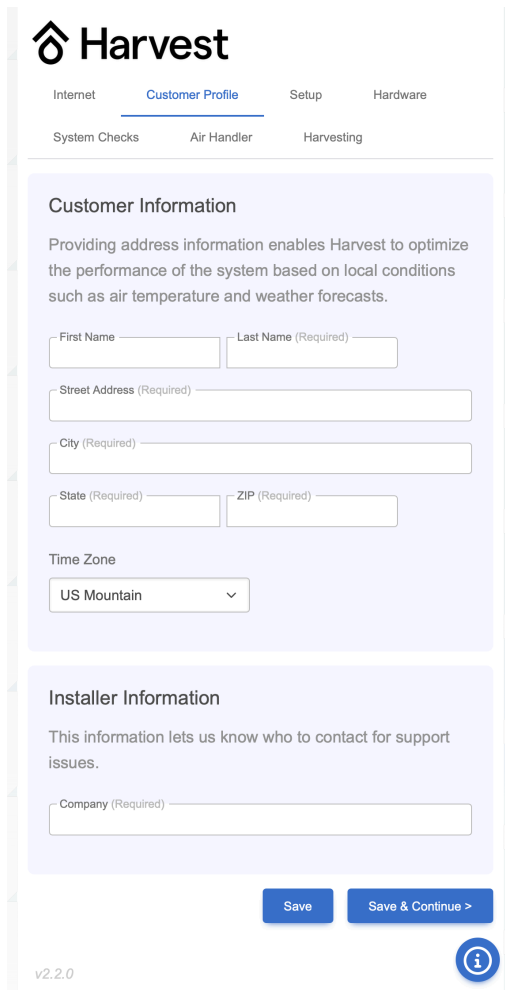

The screenshot shows the Harvest web interface for setting up a customer profile. At the top, there is a navigation menu with 'Customer Profile' selected. Below the menu, the page is titled 'Customer Information' and includes a brief explanation of why address information is needed. The form contains several input fields: 'First Name', 'Last Name (Required)', 'Street Address (Required)', 'City (Required)', 'State (Required)', and 'ZIP (Required)'. A 'Time Zone' dropdown menu is set to 'US Mountain'. Below this is the 'Installer Information' section, which has a 'Company (Required)' field. At the bottom of the form, there are two buttons: 'Save' and 'Save & Continue >'. The version number 'v2.2.0' and an information icon are located at the bottom left and right of the page, respectively.

Harvest

Internet **Customer Profile** Setup Hardware

System Checks Air Handler Harvesting

Customer Information

Providing address information enables Harvest to optimize the performance of the system based on local conditions such as air temperature and weather forecasts.

First Name Last Name (Required)

Street Address (Required)

City (Required)

State (Required) ZIP (Required)

Time Zone

US Mountain

Installer Information

This information lets us know who to contact for support issues.

Company (Required)

v2.2.0 

6 Setup the pod:

1. Confirm you have installed the SANCO2 heat pump and the tank
2. Fill in the correct Optional DX heat pump and Air Handler Protocol
3. Tap “Apply”

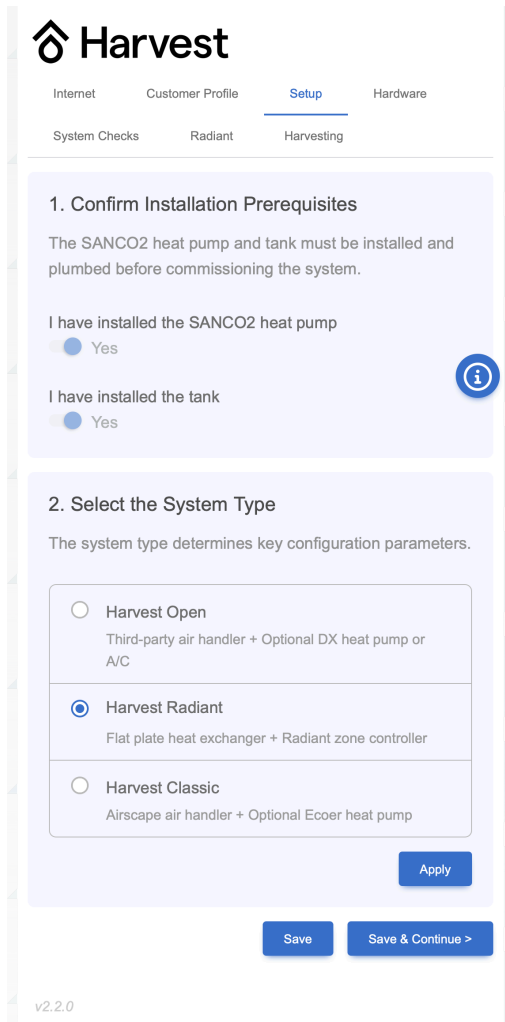

7

Select the appropriate installed hardware:

- The generation can be found in the model number shown on the nameplate of the SANCO2.
- “Number of heat pumps” refers to the number of SANCO2 Heat Pump Water Heaters installed.
- F-SAN and T-SAN are optional sensors included in the Harvest Cold Weather Kit and/or the Twin SANCO2 Kit.

SANCO2 Heat Pump Water Heater

The SANCO2 is the primary heat pump in the Harvest system.

Generation

GS3 GS4 **GS5**



Number Of Heat Pump Water Heaters

One ▾

Storage Tanks

The Harvest system stores energy in one or two hot water tanks. Indicate how many storage tanks and their capacity. For a secondary tank, just indicate its capacity (in gallons).

Primary Tank

SanCO2 119 ▾

Diameter Outer
28 Inches

Height Outer
63.6 Inches

Volume
119 Gallons

Volume Above T4
42 Gallons

Secondary Tank

Not Installed

Volume
0 Gallons

Heat Exchanger

Provide heat exchanger configuration details.

Heat Exchanger Pipe Diameter

3/8" **1/2"** 3/4"

Total Pipe Length Pod-Heat Exchanger-Pod

25 Feet

Radiant Technology

Describe the technology used for radiant heat distribution. This information is used for support purposes.

Radiant Distributor Type

Radiant Floor: "Tube Technology"

Warmboard

Other

Number Of Zones

1

Circulator Brand And Model

B&G

Radiant Floor Sensor

Radiant loop temperature sensor is needed to help commission radiant floors.

Radiant Loop Supply Water Temperature (T8)

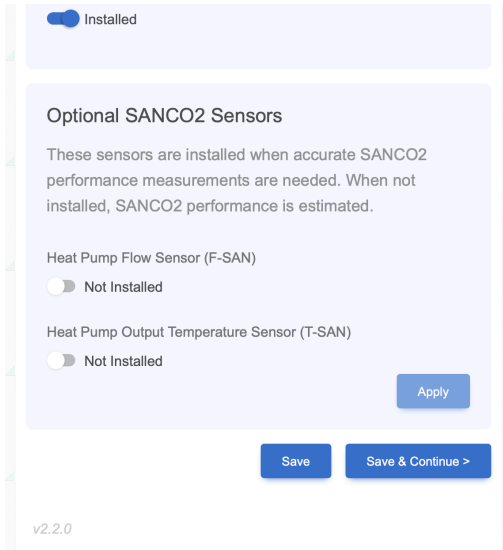

8 Check sensors and thermostat for proper function:

1. Ensure all listed sensors are indicated as “OK”

1. Sensor Check

Use this information to validate that sensors are reading properly.
Sensors update every 64 seconds.
Next Update in 48s

TEMPERATURE (F)

T-CAL	Calibration	89.6	OK
T-HOT	Hot water to heating and pre-mix DHW	143.1	OK
T-CLD	Cold water from main	49.9	OK
T-RTN	Cold water return from heating	77.3	OK
T-TNK	Mid-tank water temperature		Cannot be read in Basic mode
T-SCW	Cold water to SANCO2	50.0	OK
T-OAT	Outdoor air temperature	49.7	OK
T-DHW	Post-mix DHW supply temp	106.9	OK

FLOW (GAL)

F-DHW	Domestic hot water (DHW) usage	0.00	OK
F-HTR	Hot water flow to heating	6087.90	OK

POWER (W)

P-SAN	Power draw by SANCO2	944	OK
P-AHU	Power draw by air handler	116	OK
P-HPAC	Power draw by heat pump A/C	2537	OK

9

Test the SANCO2 wiring:

1. Select “Enable Manual Control”
2. Toggle the SANCO2 on

The SANCO2 should turn on, and the power draw should read over 500 W. This will take 3-5 minutes.

2. SANCO2 Wiring Check

Validate that the wiring to the SANCO2 is all good and that the SANCO2 responds to control signals.

[Start Wiring Check](#)

1. Toggle the SANCO2 on or off
 On
0 sec / 256 sec (0%)
2. The SANCO2 will draw about 1000 W when on; 0 W when off
Current power draw: ---
Next Update in 48s

10

Test the hydronic circulator pump to ensure it is fully purged of air:

1. Ensure Manual Control is enabled.
2. Enter 40 and select “Start”. The circulator pump inside of the Pod should turn on, and the app should display flow after 1-2 minutes.
3. If no flow is displayed, check that the loop is fully purged and that all valves are open.

3. Pod Circulator Purge Check

Use this section to validate that the circulator pump has been properly purged of air and is running when set to run.

[Start Purge Check](#)

1. Measure water flow rate in heating loop

Set pod circulator pump speed to a value between 40% and 50%. Wait for up to 2 minutes for the flow rate to stabilize.

[Stop](#)
2. The flow rate should be greater than 0.1 GPM after stabilizing

Current flow rate: ----

Next Update in 48s

[Save](#)
[Save & Continue >](#)

v2.2.0

11

Configure the radiant flow rates:

Enter home Design Heating Temperature (99% coldest temperature in Fahrenheit) and heating load at the design temperature (in kBTU/h) in order to configure the hydronic variable heat output.

1. Configure Heat Output

Per ASHRAE, design heating temperature is 99% of the coldest hourly temperature. Design heating load for this home is the Manual J heating load at design temperature.

Design Heating Temperature

 °F

Design Heating Load

 kBTU/h

2. Calibrate Heat Delivery

Calibrate heat delivery in Maximum Heat mode.

Start Calibration

1. Set the maximum allowable water return temperature to the tank

As return water temperature increases, heat output increases, but SANCO2 capacity and efficiency decrease.
Recommended: 85 °F. Allowed range: 70 °F - 100 °F.

Max Temp (°F) **Update**

2. Call for maximum heat by switching on all zone thermostats

3. Adjust Harvest Pod and radiant circulator speeds

Adjust the Harvest Pod circulator speed AND the radiant circulator speed (using controls on the radiant circulator) to achieve your target heat transfer while maintaining the Harvest return temperature below 85 °F (the max temperature set above).

Pod Circulator Speed **Start**

Heat Exchanger	Harvest Loop	Radiant Loop
Flow	0.00 GPM	<input type="text"/> GPM
Supply Temp	142.1 °F	106.4 °F
Return Temp	76.9 °F	N/A - Enter radiant flow
Heat Transfer	0 BTU/h	

3. Calibrate Basic Mode

Basic mode is a fallback mode in case of an electronics or sensor issue. It uses a fixed circulator pump speed that needs to be calibrated.

Start Calibration

1. Switch on all zone thermostats to call for maximum heat

2. Calibrate circulator pump for 10,000 BTU/h

Keeping the same radiant circulator setting, adjust the Pod Circulator Speed below to get as close to 10,000 BTU/h as possible, while maintaining the Harvest Loop return temperature below the maximum set while calibrating heat transfer. Each adjustment requires 2 minutes for the flow rate to stabilize.

Pod Circulator Speed **Update**

Heat Exchanger	Harvest Loop	Radiant Loop
Flow	0.00 GPM	<input type="text" value="GPM"/>
Supply Temp	142.1 °F	106.4 °F
Return Temp	76.9 °F	N/A - Enter radiant flow
Heat Transfer	0 BTU/h	

Next Update in 6s..

[Save](#) [Save & Continue >](#)

v2.2.0

12 Configure Energy Harvesting

1. Select Time of Use Control
2. Select Utility Rate Schedule based on customers' current or requested utility rate.
3. Select "EcoPort is integrated into the pod."

Harvest

Internet Customer Profile Setup Hardware

System Checks Air Handler **Harvesting**

1. Select Harvesting Mode

1. Select Harvesting Mode

None

Time of Use Control

Advanced Demand Response Control

2. Select Utility Rate Schedule

CA PG&E E-EV2A

3. Configure EcoPort

No EcoPort or Adapter

EcoPort is integrated into the pod

EcoPort adapter is connected to the pod via RJ45 (ethernet) cable

EcoPort adapter is connected to the local network

August 18, 2025 Pod0024

[Format For Screenshot](#) [Save](#)

v2.2.0

Troubleshooting

Danger

ELECTRICAL SHOCK HAZARD: Confirm all circuits are de-energized before performing any wiring activity

- › **Check All Wiring, Particularly Any Connections. Gently Pull On Wire Connections To The Pod And Heat Pump To Make Sure They Are Tight.**
- › **Check That The Water Is On, All Valves Are Open, And There Are No Leaks**
- › **The SANCO2 Heat Pump Does Not Turn On**
- › **SANCO2 Control Panel Displays H7**
- › **Tank Temperature Sensor Reading Above 120°F After Heat Pump Has Completed A Full Charge (Heat Pump Has Stopped):**
 - › **Chemical Smell In Water**
- › **For Issues Relating To Units Within The System Such As The Air Handler, Refer To The Manufacturer's Documentation And/Or Website For Guidance**